

INSTRUCTION MANUAL

CHEMTROL™ PC PROGRAMMABLE CONTROLLERS

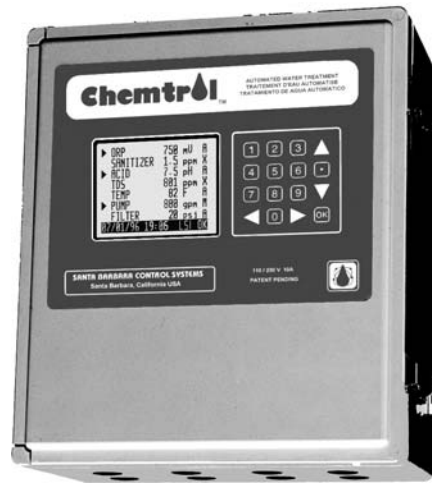

MODEL _____

S/N _____

WARRANTY

This CHEMTROL™ Controller is warranted by SANTA BARBARA CONTROL SYSTEMS (SBCS) to be free from defects in manufacturing and workmanship for a period of FIVE (5) YEARS from the date of purchase for the printed circuit boards and ONE (1) YEAR for all other components. SBCS will repair or replace at its option any defective part during the warranty period. Labor, shipping or incidental expenses are specifically excluded from this warranty. For warranty coverage, defective parts should be returned immediately to your CHEMTROL™ Dealer or to our factory postpaid with a copy of your purchase receipt and a description of the malfunction.

TECHNICAL SUPPORT	
US/CANADA	800-621-2279
OTHER COUNTRIES	805-683-8833
FAX	805-683-1893
INTERNET	support@sbcontrol.com



SANTA BARBARA CONTROL SYSTEMS
5375 Overpass Road – Santa Barbara, CA 93111

MENU TREE CHEMTROL™ PC6000 & PC3000

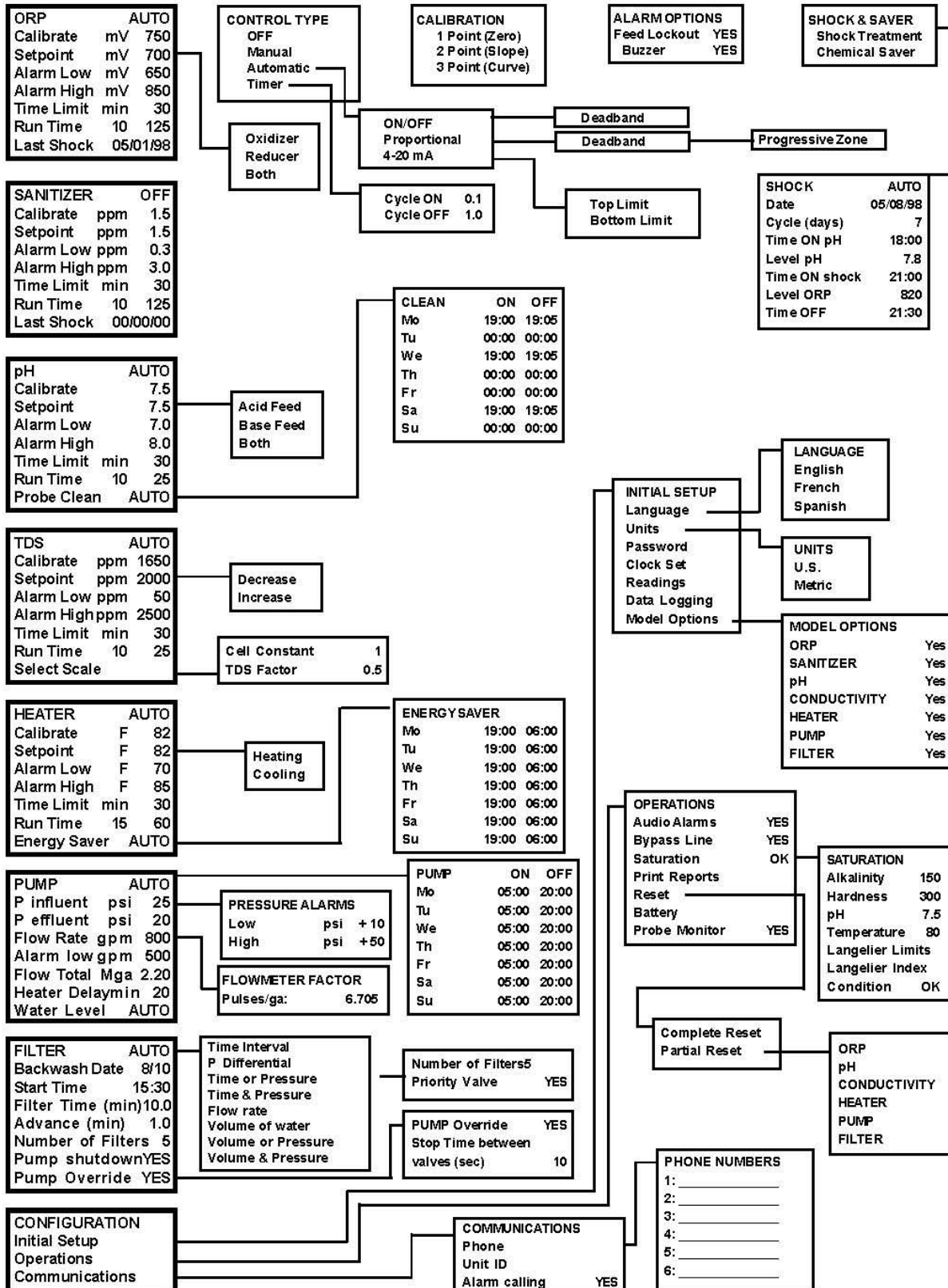

IMPORTANT SAFETY INSTRUCTIONS

Specified by ITS Testing Services for Swimming Pools and Spas

1. **READ AND FOLLOW ALL INSTRUCTIONS**

2. **WARNING** - To reduce the risk of injury, do not permit children to use this product unless they are closely supervised at all times.

3. A wire connector is provided on this unit to connect a minimum No. 8 AWG solid copper conductor between this unit and any metal equipment, metal enclosures or electrical equipment, metal water pipe or conduit within 5 feet of this unit.

4. **DANGER** - Risk of injury.
a) Replace damaged cord immediately.
b) Do not bury cord.
c) Connect to a grounded, grounding type receptacle only.

5. **WARNING** - This product must be connected to a power source equipped with a ground-fault circuit interrupter (GFCI). The GFCI must be tested before each use. With the product operating, open the service door. If the product stops operating, this merely indicates that the door is equipped with an electrical interlock. Next, push the test button on the GFCI and close the service door. The product should not operate. Now open the service door, push the reset button on the GFCI and close the service door. The product should now operate normally. If the product fails to operate in this manner, there is a ground current flowing indicating the possibility of an electric shock. Disconnect the power until the fault has been identified and corrected.

8. **DANGER** - Risk of electric shock. Install at least 5 feet (1.5 m) from inside wall of tub or spa using nonmetallic plumbing.

7. **DANGER** - Risk of electric shock. Do not permit any electric appliance, such as a light, telephone, radio, or television, within 5 feet (1.5 m) of a spa or hot tub.

8. **WARNING** - To reduce the risk of injury:

a) The water in a spa should never exceed 40 °C (104 °F). Water temperatures between 38 °C (100 °F) and 40 °C (104 °F) are considered safe for a healthy adult. Lower water temperatures are recommended for young children and when spa use exceeds 10 minutes.

b) Since excessive water temperatures have a high potential for causing fetal damage during early months of pregnancy, pregnant or possibly pregnant women should limit spa water temperatures to 38 °C (100 °F).

c) Before entering a spa or hot tub, the user should measure the water temperature with an accurate thermometer since the tolerance of water temperature-regulating devices varies.

d) The use of alcohol, drugs or medication before or during spa or hot tub use may lead to unconsciousness with the possibility of drowning.

e) Persons suffering from obesity or with a medical history of heart disease, low or high blood pressure, circulatory system problems or diabetes should consult a physician before using a spa.

f) Persons using medication should consult a physician before using a spa or hot tub since some medication may induce drowsiness while other medications may affect heart rate, blood pressures and circulation.

9. **SAVE THESE INSTRUCTIONS**

TABLE OF CONTENTS

IMPORTANT SAFETY INSTRUCTIONS.....	iii	Storage and Winterizing.....	15
TABLE OF CONTENTS	iv	Sensor Warranty	15
LIST OF FIGURES	vi	TEMPERATURE SENSOR	15
CHAPTER I - INTRODUCTION.....	1	CONDUCTIVITY SENSOR.....	15
Water Maintenance	1	FLOW SENSOR.....	16
Reference Manuals	1	Flow Sensor Location	16
CONTROLLER FEATURES	2	Flow Sensor Saddles	16
Automated Water Treatment	2	Flow Sensor Connections	16
Control Functions	2	PRESSURE TRANSDUCERS.....	17
Probe Failure Analysis	2	Transducer Connections	17
CONTROL PANEL	3	WATER LEVEL SENSOR	17
LCD Display Screen	3	Installation.....	17
Display Readings	3	Maintenance	17
Data Entry Keyboard.....	3	Figure 25 - Optical Level Sensor.....	17
Remote Communications.....	3	CHEMICAL FEEDERS	18
PROGRAM MENUS	4	WARNING: Tank Sizing.....	18
Initial Screens.....	4	Chemical Feed Pumps.....	18
Display Screens	4	Carbonic Acid (CO ₂) Valve.....	18
Main Menus and Submenus.....	4	Gas Chlorinator.....	18
Alarm Displays	4	Erosion Feeders.....	18
CHAPTER II - INSTALLATION.....	5	Back Diffusion.....	18
SAFETY NOTICE	5	FILTER BACKWASH.....	19
UNPACKING	5	Main Pump Shutoff	19
INSTALLATION & WARRANTY REPORT.....	5	Single Filter Backwash.....	19
TECHNICAL SUPPORT	5	Multiple Filter Backwash	19
PRINCIPLE OF INSTALLATION	5	Backwash Stager	19
CONTROLLER CABINET.....	5	Electrical Valves.....	19
LOCATION	5	Hydraulic Valves	19
ELECTRICAL.....	7	Pneumatic Valves	19
Electrical Codes	7	CONTROLLER STARTUP	20
AC Power Input	7	Initial Reset	20
Grounding (GFI).....	7	Configuration Menu.....	20
Main Power Interlock.....	7	Alarm Buzzer	20
Panel Interlock	7	Bypass Line	20
PC Boards.....	7	Battery Check	20
Power Board	7	CHEMICAL CONTROL	20
115V/230V Power Transformer	7	Initial Activation of Sensors	20
Relay Jumpers (PC6000).....	7	Bypass Line Test	20
Relays and Fuses.....	9	Water Chemistry Adjustment	20
Remote Alarm	9	Water Sampling	20
Mother Board	9	pH Calibration	20
Sensor Connections.....	9	pH Feed (Acid or Base)	21
Buzzer	9	pH Setpoint	21
Display Brightness.....	9	ORP Calibration.....	21
Backup Battery.....	10	ORP Setpoint	21
Remote Communications.....	10	Sanitizer Calibration.....	21
Multiple Serial Connections.....	10	Time Limits.....	21
4-20 mA Converter Boards.....	11	Shock Treatment.....	21
Field Installation	11	Chemical Saver.....	21
4-20 mA Connections.....	11	WATER SATURATION	21
PLUMBING	12	CHAPTER I V - CONTROLLER OPERATION	22
Installation of Sensors	12	Access	22
In-line Installation (2" Pipe).....	12	Default Setup	22
Bypass Line Installation.....	12	8 - CONFIGURATION MAIN MENU	22
Flow Cell Assembly (Option)	13	8.1 - INITIAL SETUP SUBMENU	23
Sensor Cell Cabinet (Option)	13	8.1.1 - Language	23
Water Flow	13	8.1.2 - Units	23
Paddle Wheel Rotary Flow Switch	13	8.1.3 - Code Number	23
WATER CHEMISTRY SENSORS	14	8.1.4 - Clock	24
Sensor Properties	14	8.1.5 - Readings	24
ORP Sensor	14	8.1.6 - Data Logging.....	24
pH Sensor	14	8.1.7 - Model Options	24
Sensor Installation.....	14	8.2 - OPERATIONS SUBMENU	25
Sensor Cables.....	14	8.2.1 - Audio Alarms.....	25
Electrical Interference.....	14	8.2.2 - Bypass Line.....	25

8.2.3 - Langelier Saturation Index.....	25	5.7 - Run Time	37
8.2.4 - Print Reports.....	26	5.8 - Energy Saver	37
8.2.5 - Reset	27	6- PUMP MENU	38
8.2.6 - Backup Battery	27	Operation	38
8.2.7 - Probe Monitor	27	6.1- Control Mode	38
8.3 - COMMUNICATIONS SUBMENU.....	28	6.2 - Influent Pressure.....	39
8.3.1 - Phone Numbers.....	28	Pressure Alarms.....	39
8.3.2 - Unit Identification	28	Calibration	39
8.3.3 - Alarm Calling	28	6.3 - Effluent Pressure	39
8.3.4 - 4-20 mA Signal Output	28	Differential Pressure	39
1 - ORP MENU	29	6.4 - Flow Rate	40
Operation	29	6.5 - Low Alarm	40
1.1 - Control Mode.....	29	6.6 - Flow Total	40
1.2 - Display and Calibration	29	6.7 - Heater Delay (Cooldown Safety)	41
1.3 - Setpoint.....	29	6.8 - Water Level Control	41
1.4 - Low Alarm	29	The sensor is an electro-optical sensor (.....	41
1.5 - High Alarm	30	6.8.2 - Feed lockout.....	41
1.6 - Time Limit	30	6.8.3 - Time limit.....	41
1.7 - Run Time	30	6.8.4 - Run time.....	41
1.8 - Last Shock	30	6.8.5 - Alarm High (PC6000 model only)	41
1.8.1 - Shock Treatment	30	7 - FILTER MAIN MENU	42
1.8.2 - Chemical Saver	30	Filter Backwash.....	42
2 - SANITIZER MENU	31	7.1 - Automatic Backwash.....	42
Operation	31	7.1.1 - Time Interval	43
PPM Readings	31	7.1.2 - Pressure Differential.....	43
2.1 - Display and Calibration	31	7.1.3 - Time or Pressure Differential.....	43
2.1.1 - One-Point Calibration	31	7.1.4 - Time and Pressure Differential.....	43
2.1.2 - Two-Point Calibration	31	7.1.5 - Flow Rate	43
2.3 - Setpoint.....	32	7.1.6 - Volume of Water.....	44
2.4 - Low Alarm	32	7.1.7 - Volume or Pressure Differential.....	44
2.5 - High Alarm	32	7.1.8 - Volume and Pressure Differential.....	44
2.6 - Time Limit	32	7.6 Priority Valve.....	44
2.7 - Run Time	32	7.7 Pump Shutdown.....	44
2.8 - Last Shock	32	7.8 Pump Override.....	44
2.8.1 - Shock Treatment	32	CONTROL SUBMENUS.....	45
2.8.2 - Chemical Saver	32	Features.....	45
3 - pH MENU	33	X.1 - Control Type.....	45
Operation	33	X.0.1 - Deadband	45
3.1- Control Mode.....	33	X.0.2 - Progressive Zone.....	45
3.2 - Display and Calibration	33	X.1.3 - Automatic Control	46
3.3 - Setpoint.....	33	X.1.4 - Timer Control	46
3.4 - Low Alarm	34	CALIBRATION SUBMENUS	47
3.5 - High Alarm	34	X.2 - Calibration Options.....	47
3.6 - Time Limit	34	X.2.1 - One-Point Calibration.....	47
3.7 - Run Time	34	X.2.2 - Two-Point Calibration.....	47
3.8 - Probe Clean	34	X.2.3 - Three-Point Calibration	47
4 - CONDUCTIVITY MENU	35	SHOCK AND SAVINGS SUBMENUS	48
Conductivity and TDS.....	35	X.8 - Treatment Selection	48
Conductivity or TDS Displays.....	35	X.8.1 - Shock Treatment Program.....	48
4.1- Control Mode.....	35	X.8.2 - Chemical Saver Program.....	48
4.2 - Display and Calibration	35	CHAPTER V - COMMUNICATIONS.....	49
4.3 - Setpoint.....	35	CHEMCOM™ REMOTE OPERATION	49
4.4 - Low Alarm	35	CHEMCOM™ Program.....	49
4.5 - High Alarm	35	Computer Software Installation.....	49
4.6 - Time Limit	36	Remote Communications.....	49
4.7 - Run Time	36	Modem Connections	49
4.8 - Select Scale	36	Ethernet / Internet Connections.....	50
4.8.1 - Scale Selection.....	36	Direct Connections	50
4.8.2 - Cell Constant	36	Remote Operation.....	50
4.8.3 - TDS Factor	36	Scanning Facilities	51
5 - TEMPERATURE MENU	37	Data Log Download	52
Operation	37	Text Data Display.....	52
5.1 - Control Mode.....	37	Graphic Data Display	52
5.2 - Display and Calibration	37	CHAPTER VI - MAINTENANCE	53
5.3 - Setpoint.....	37	CONTROLLER MAINTENANCE	53
5.4 - Low Alarm	37	Regular Maintenance	53
5.5 - High Alarm	37	The Acid Test.....	53
5.6 - Time Limit	37	Sensor Cleaning	53

Winterizing 53
 Battery Replacement 53
 Software Upgrade 53
 CHEMICAL MAINTENANCE 54
 Overview 54
 pH Control 54
 ORP and Sanitizer Control 54
 Limit Timers (Overfeed Safety) 55
 Timer Settings 55
 PERIODIC MAINTENANCE 55
 Water Testing 55
 Shock Treatment 55
 Precautions 55
 PORTABLE TESTER 56
 The PORTA-PROBE™ 56
 Battery Check 56
 Self-Test 56
 Testing of Sensors 56
 Testing the Controller 57
 TROUBLESHOOTING 58
 PARTS, ACCESSORIES AND UPGRADES 59
 INDEX 60

Figure 8 - Power Board 8
 Figure 9 - Multiplex Connections 10
 Figure 10 - Installation of 4-20 mA Boards 11
 Figure 11 - 4-20 mA Converter Board 11
 Figure 12 - Sensor Installation 12
 Figure 13 - Bypass Line assembly 12
 Figure 14 - Flow cell Assembly (Option) 13
 Figure 15 - Sensor Cell Cabinet (Option) 13
 Figure 16 - ORP and pH Sensors 14
 Figure 17 - Temperature Sensor 15
 Figure 18 - Conductivity Sensor 15
 Figure 19 - Flow Sensor Installation 16
 Figure 20 - Model 2536 Flow Sensor 16
 Figure 21 - Model 2540 Flow Sensor 16
 Figure 22 - Saddle for FS2536 16
 Figure 23 - Saddle for FS 2540 16
 Figure 24 - Pressure Transducer 17
 Figure 25 - Optical Level Sensor 17
 Figure 26 - Optical Beam Path 17
 Figure 27 - Water Level Assembly 17
 Figure 28 - Erosion Feeder Control 18
 Figure 29 - Single Filter Backwash 19
 Figure 30 - Multiple Filter Backwash 19
 Figure 31 - Data Log 26
 Figure 32 - Proportional Feed Rate 46
 Figure 33 - CHEMCOM™ Program Menu 49
 Figure 34 - CHEMCOM™ Facility Selection 50
 Figure 35 - CHEMCOM™ Remote Operation Screen 50
 Figure 36 - CHEMCOM™ Automatic Scanning 51
 Figure 37 - CHEMCOM™ Text Data Display 52
 Figure 38 - CHEMCOM™ Graphic Data Display 52
 Figure 39 - Portable Tester 56

LIST OF FIGURES

Figure 1 - PC3000 Controller 2
 Figure 2 - PC6000 Controller 2
 Figure 3 - Control Panel 3
 Figure 4 - Remote Computer 3
 Figure 5 - Schematic of Installation 6
 Figure 6 - Controller Cabinets 6
 Figure 7 - Mother Board 8

CHAPTER I - INTRODUCTION

Congratulations on your selection of the CHEMTROL™ PC Programmable Controller for your water treatment facility.

CHEMTROL™ Automation uses advanced electronic sensing technology to monitor and control the most control critical parameters in water, such as sanitizer activity, pH, temperature, conductivity or total dissolved solids (TDS). These are all essential to maintaining safe and enjoyable water.

Water Maintenance

The primary purpose of water maintenance is to maintain clean and safe water that meets the bacteriological and physiological requirements of state and local Health Departments, as shown, for example, in the table for the State of California.

Equally important is protection of the equipment from the aggressiveness of water and its constituents.

The guidelines adopted by the National Spa and Pool Institute (NSPI), as shown in the second table.

For chemical automation, we recommend:

- adequate filtration with a maximum turnover rate of six hours for a pool or 30 minutes for a spa,
- proper water balance with a pH between 7.4 and 7.6, alkalinity between 80 and 120 ppm (mg/l) and Langelier Saturation Index between 0 and 0.3,
- proper sanitation with an Oxidation-Reduction Potential (ORP) above 650 mV and a cyanuric acid level below 40 ppm (mg/l),
- proper water quality with Total Dissolved Solids (TDS) less than 1,500 ppm (mg/l).

The CHEMTROL™ PC is designed to automate and facilitate the attainment of these goals.

Reference Manuals

For more information on water treatment, see the Maintenance section in this Instruction Manual or refer to one of the following reference manuals:

- **“Basic Pool and Spa Technology”**
National Spa and Pool Institute (NSPI)
- **“Pool/Spa Operators Handbook”**
National Swimming Pool Foundation (NSPF)
- **“Aquatic Facility Operator Manual”**
National Recreation and Park Association (NRPA).

1986 CALIFORNIA HEALTH CODE for Swimming Pools	
CLARITY	Main drain to be visible from deck.
STANDARD PLATE COUNT at 35 ^o , per ml	Less than 200 Bacteria
TOTAL COLIFORM COUNT per 100 ml	Less than 2.2 organisms
PHYSIOLOGICAL QUALITY	No eye or skin irritation. No objectionable physiological effect.

TEST	MIN	IDEAL	MAX
pH	7.2	7.5	7.6
FREE CL, ppm			
Non-stabilized	1	1.5	2
Stabilized	1.5	2	3
Spa	2	3	5
COMBINED CL, ppm	0	0	0.2
BROMINE, ppm	2	3	4
OZONE, ppm	0.01	-	1
ORP, mV	650	750	-
CYANURIC ACID, ppm			
Outdoor Pool	3000	4000	10000
Indoor Pool			0
Spa			
TOTAL ALKALINITY, ppm	100	125	150
TDS, ppm	300	1000	3000
Based on Standards for Public Pools and Spas. Published in 1988 by the NATIONAL SPA AND POOL INSTITUTE			

CONTROLLER FEATURES

Automated Water Treatment

The CHEMTROL™ PC 3000 (Figure 1) and PC6000 controllers (Figure 2) are advanced automation systems for water maintenance. Designed around a sophisticated microprocessor, the controller displays user-friendly menus and submenus on an easy-to-read LCD (Liquid Crystal Display) screen. All the displays and adjustments are accessible from menu screens that are laid out in a logical and intuitive order. They can in fact be used without reference to the instruction manual.

All sensing devices are connected to the central control module. That makes it possible to monitor the status of all operational parameters at a glance. Also, in case of malfunction or alarm, the operator is immediately alerted.

Control Functions

The following display and control functions are available on the CHEMTROL™ PC 3000 and PC6000 controllers:

- **Oxidation-Reduction Potential (ORP or Redox)** in millivolts with programmable oxidizer feed, shock treatment and chemical savings program,
- **Sanitizer Concentration** in parts per million (ppm) or milligrams per liter (mg/l) with programmable sanitizer feed, shock treatment and chemical savings program,
- **pH** from 0 to 14 with capability for acid and base feed,
- Selectable **Conductivity** in microsiemens/cm or **Total Dissolved Solids (TDS)** in ppm or mg/l with capability for programmable dumping of water or addition of a saline solution for chlorine salt generators,
- **Heater Control** with temperature display in degrees Fahrenheit or Celsius, programmable heater control and energy savings program,
- **Water Recirculation** with automatic programming or manual control of main pump plus display of flow rate in gallons per minute (gpm) or liters per minute (l/m) and totalizer in Millions of Gallons (Mga) or cubic meters (m3),
- **Water Balance and Saturation Condition** derived from the **Langelier Saturation Index** and showing water balance conditions as either OK, corrosive or scaling.
- **Filtration** with display of inlet and outlet pressure and eight programmable filter backwashing (PC6000 only) based on choice of time, pressure differential, flow rate, volume of water since last backwash or combinations of the above.

In addition, a 24-hour clock/calendar shows the date and time on the main screen. For models that do not include all the functions listed above, only the applicable screens and menus are to be used.

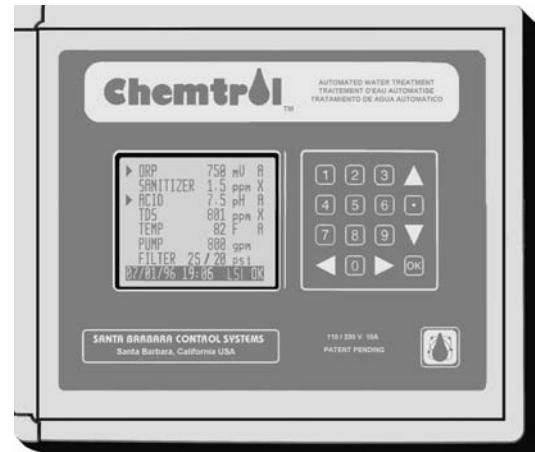

Figure 1 - PC3000 Controller



Figure 2 - PC6000 Controller

Probe Failure Analysis

All PC CHEMTROL™ PC controllers include the exclusive safety feature called Probe Failure Analysis.

With this proprietary technology (US Patent No. 5,895,565), the controller continuously monitors and tests the dynamic response of the ORP and pH sensors (see page 27). This important feature allows early detection of probe failure, thereby avoiding the dangerous out-of-range conditions that can develop with other controllers.

Other controllers have to wait until there is an out-of-range or an alarm condition in order to alert the operator. This could result in serious damage and liability.

Figure 3 - Control Panel

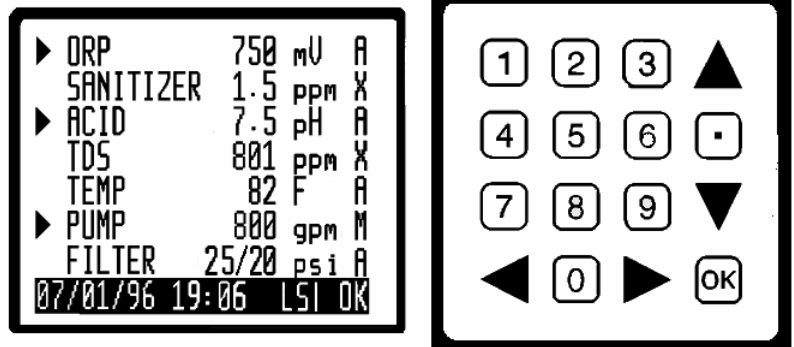

CONTROL PANEL

LCD Display Screen

The operator interacts with the controller with the LCD display screen and the 16-key data entry keyboard on the front panel, both shown in Figure 3.

The display shows eight lines of text that can be scrolled up and down with the UP and DOWN ARROW keys to highlight each of the menu lines.

The LCD display shows either "normal" characters (black on white), or reverse characters (white on black) to highlight selected options, or also flashing characters to alert alarm conditions.

The brightness of the LCD display screen is adjusted at the factory before shipping. If required, it can be re-adjusted at any time with the potentiometer on the Mother Board (Figure 7) inside the cabinet. It is located near the center of the board and marked R39.

The LCD display screen features backlight illumination for better viewing at night and in dark areas. To protect the display, the backlight turns off automatically after a short time. It turns on again as soon as a key is pressed.

Display Readings

As shown on the Display Screen (Figure 3), the operator can check all operating parameters at a glance.

- Line 1 shows an **ORP reading of 750 mV** with the feed pump in Automatic feed mode (A) and running (>).
- Line 2 shows a **Sanitizer level of 1.5 ppm** with the feed mode OFF (X).
- Line 3 shows a **pH reading of 7.5** with the Acid feed mode in Automatic (A) and the pump not running (no >).
- Line 4 shows the **Total Dissolved Solids (TDS)** at 801 ppm and bleed valve control OFF (X).
- Line 5 shows a **Temperature reading of 82 F** with the heater control on Automatic (A).
- Line 6 shows a **Flow rate at 800 gpm** and the Pump in Manual mode (M).
- Line 7 shows an **Influent Pressure of 25 psi**, an **Effluent Pressure of 20 psi** and the backwash program in Automatic mode (A).
- Line 8 shows the **Date and Time** and an indication that the **water saturation condition is OK**. The line is highlighted to give access to the Configuration Menu.

Data Entry Keyboard

The data entry keyboard replaces the knobs and switches of conventional controllers. All operational entries such as choice of operational mode, calibration, control setpoints, alarms and programming are performed with the 16 keys of the keyboard.

The keyboard consists of a full 16-key numeric keypad. There are ten digits from "0" to "9" plus the decimal point "." for data entry.

The operator navigates through all the menus and submenus with four directional arrow keys: UP, DOWN, LEFT, and RIGHT.

Remote Communications

The CHEMTROL™ PC controller features remote operation by computer (Figure 4).

Unlike less advanced controllers that provide only simulated representation, the CHEMTROL™ PC operates in true duplex mode with full access to all menus and submenus.

This means that any change on the controller screen is immediately reproduced on the remote computer screen. And vice versa, any operation that is performed on the remote computer screen is reproduced immediately on the controller.

The same commands are available on both units. This facilitates operator training and allows instant verification and adjustment of all control parameters. Changes in parameter settings are subject to password verification to prevent unauthorized access.

Figure 4 - Remote Computer



PROGRAM MENUS

Initial Screens

When power is applied to the controller, the CHEMTROL™ PC displays the Welcome Screen shown on the right. It includes the version of operating software installed on the controller and the numbers for Technical Support from the factory by phone 805-683-8833 or by fax 805-683-1893. In the USA and Canada, technical support is also available toll-free at 800-621-2279.

These screens can also be accessed at any time from the Main Display Screen by pressing the LEFT ARROW key.

Display Screens

The Welcome Screen is followed by one of the display screens, as shown on the right. The PC6000 and PC3000 show 8 lines of display.

The Display Screen is the normal monitoring screen. It displays several lines of information, one for each operating function and one for system conditions.

The underlines _____ on this screen, and all menus and submenus, show operator adjustable entries, selections and calibrations.

Each line displays operational information on five columns, from left to right:

1. operational status (ON or OFF) with a small arrow indicating outlet activation,
2. function identification: ORP, SANITIZER, pH, CONDUCTIVITY, TEMPERATURE, PUMP and FILTER,
3. Sensor readings,
4. units of measurement (US or metric),
5. operational mode, represented by a single letter:

- A for automatic control,
- M for manual operation,
- T for timer control,
- X for OFF.

Main Menus and Submenus

As shown on the Menu Tree included in the manual, there are several Main Menus that are accessed directly from the Display Screen, one for each operating function and one for system configuration. The submenus are additional menus that are accessed from one of the main menus or other submenu.

Navigation through the menus is done with the four arrow keys located on the front panel keypad. To access any menu or submenu, use the UP and DOWN ARROW keys to highlight the desired line and press the RIGHT ARROW key. To exit from any menu or submenu, press the LEFT ARROW key.

In this chapter, each menus and submenus is identified by its on line number. It provides a road map for quick location.



Welcome Screen

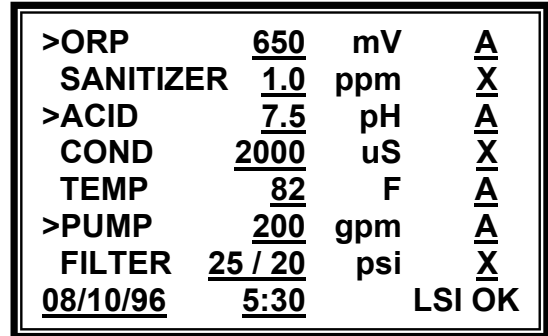

PC6000 Main Display

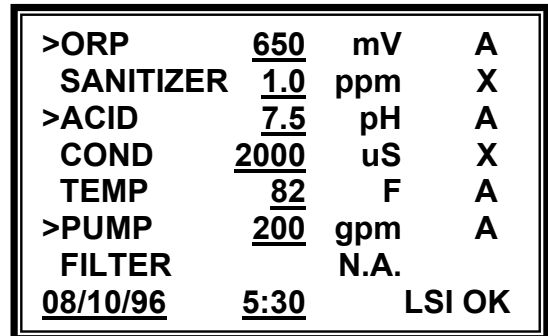

PC3000 Main Display

Alarm Displays

Probe failure, out-of-range and overfeed conditions are indicated on the Display Screen and on the Main Menus with flashing characters. For probe failure, the display flashes "Probe" on the corresponding line.

If the display shows an out-of-range or overfeed alarm condition, press the DOWN ARROW key to the flashing line and enter the submenu with the RIGHT ARROW key to determine the cause of alarm.

CHAPTER II - INSTALLATION

SAFETY NOTICE

See important safety information on the first page of the manual.

UNPACKING

Immediately upon receipt of your shipment, check the shipping carton carefully for damage and report any damage directly to the shipping company. Please report any shortage immediately to the factory.

Before opening the carton, check the outside label and verify the model number, voltage, tee size and feed mode. Unpack the carton carefully, taking care not to lose any of the smaller parts, such as PVC fittings.

The controller carton should include the following:

- Controller Cabinet,
- Sensors as required for selected model,
- Instruction Manual,
- Installation & Warranty Report to be mailed back to factory upon completion of installation,
- Bypass Line Assy (BPL) or Flow Cell Assy (FCAPWFS).

INSTALLATION & WARRANTY REPORT

The Installation Report is a triplicate form designed to assure warranty coverage, technical updates and factory support.

1. White copy: to mail back to factory.
2. Pink copy: to Facilities Manager.
3. Yellow copy: to Qualified Dealer.

Upon completion of installation, it must be filled out and signed by the Qualified Dealer and by the facilities manager.

TECHNICAL SUPPORT

Please take the time to read this detailed Instruction Manual to insure proper installation and operation. If you need further technical assistance, you can contact your Qualified CHEMTROL™ Representative, call our Technical Department toll free at 800-621-2279 or e-mail us at support@sbcontrol.com.

PRINCIPLE OF INSTALLATION

The CHEMTROL™ PC constitutes an integrated command center for complete monitoring and control of all water treatment operations, including chemistry, filtration, heating recirculation pump and water level.

All information provided by the sensors is processed by the microprocessor on the Mother Board and displayed on the Main Display screen. Command signals are then sent to the different control outputs on the Power Board (see ELECTRICAL below).

The schematic of installation in Figure 5 shows the principle of installation for the CHEMTROL™ PC6000 with all options installed. Figure 13, Figure 14 and Figure 15 show the details of installation for the bypass line, flow cell assembly, and sensor cell assembly.

CONTROLLER CABINET

The CHEMTROL™ PC controller is contained in a rain proof and splash proof NEMA Type 4X cabinet.

The external dimensions of the cabinets and the positioning of the mounting holes are shown in Figure 6.

For ease of installation, there are two external mounting ears on the top of the cabinet.

All the electronic and electrical components are mounted inside the cabinet on two separate PC Boards, the Mother Board (Figure 7) and the Power Board (Figure 8). Outlets are provided on the bottom of the cabinet for 1/2" conduits connectors.

LOCATION

Mount the cabinet on a wall in a secure location:

- more than 10' (3 m) away from the water edge to comply with electrical code requirements,
- within 10' (3 m) of the main recirculation line or of the bypass line - unless special extension cables are used for the sensors (see Sensor Cables),
- not exposed to direct sunlight as the LCD display screen will darken at high temperature,
- easily accessible to maintenance personnel,
- if possible in a separate room, or in a well-ventilated room as far away as possible from corrosive chemicals and storage tanks,
- at a safe distance from power transformers, pump motors or high voltage power lines,
- safe from unauthorized access or vandalism

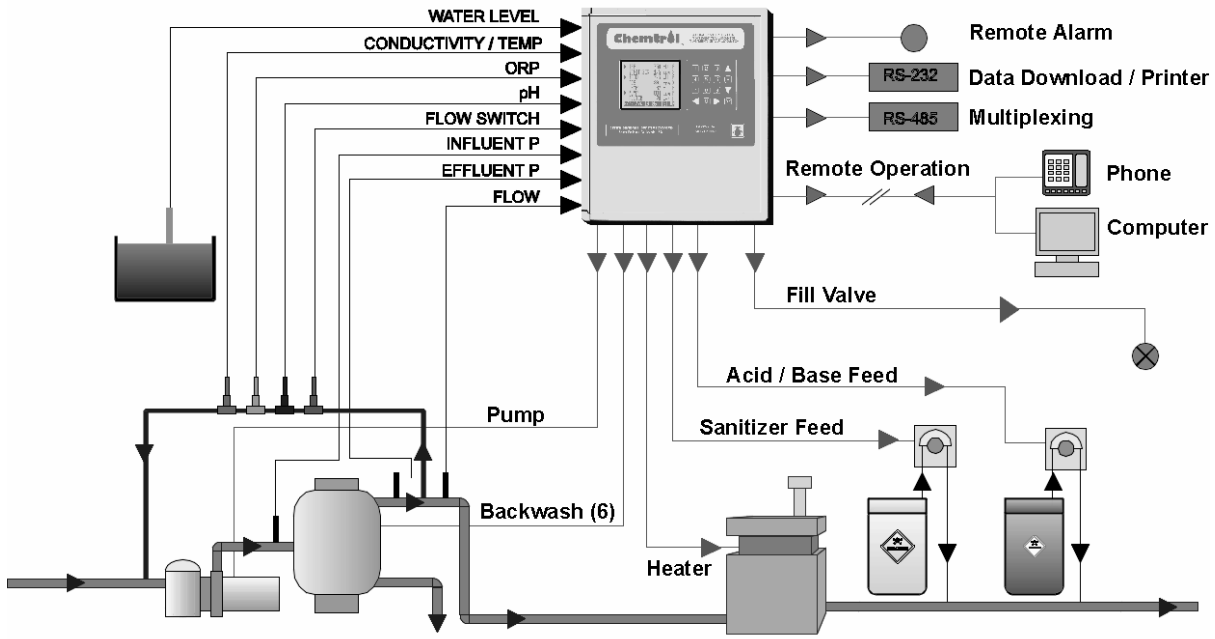

Figure 5 - Schematic of Installation

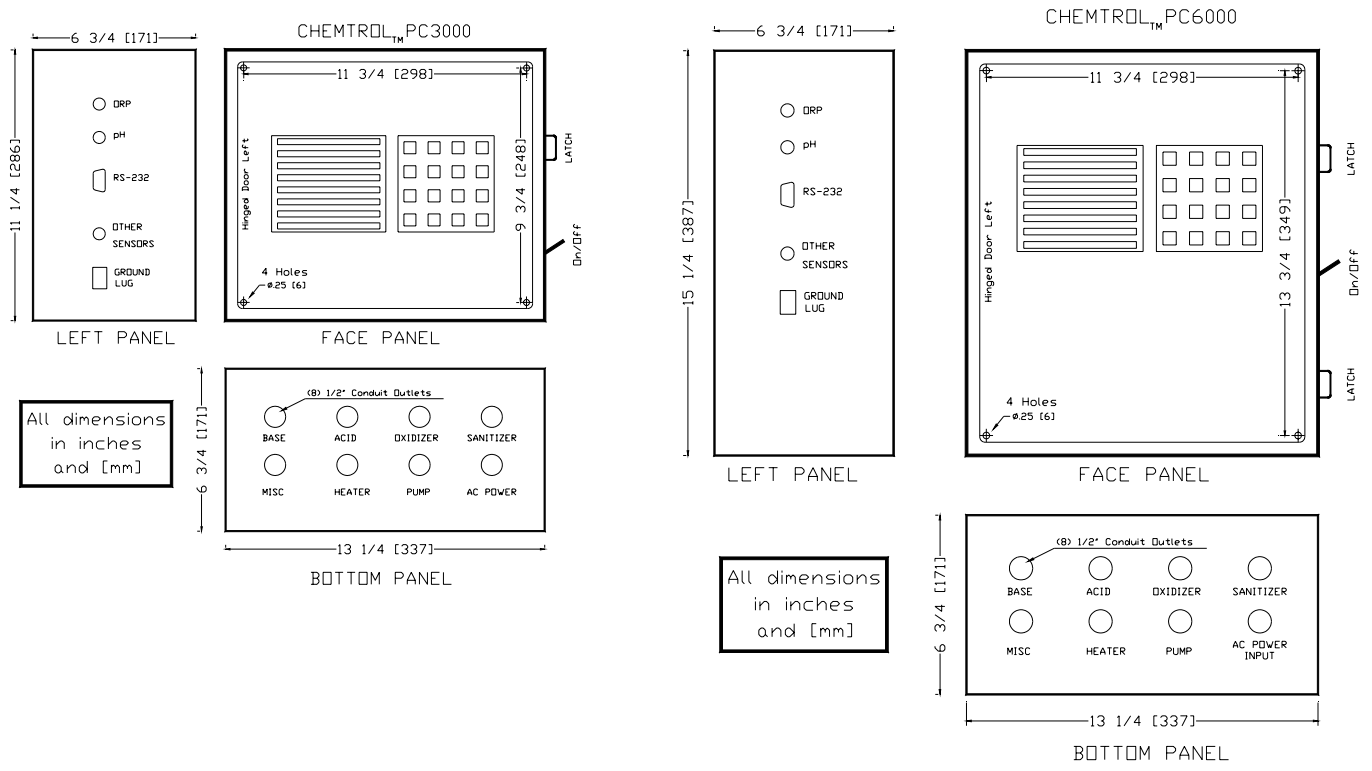

Figure 6 - Controller Cabinets

ELECTRICAL

Electrical Codes

**INSTALLATION MUST FOLLOW
ALL APPLICABLE ELECTRICAL CODES**

The controller is available in either hard-wiring or plug-in configurations. Make sure to use the proper type of wiring according to the local electrical code, usually the same as for the chemical feeders.

The internal wiring and labeling for the Power Board of the controller (Figure 8) are as follows:

		RELAYS	POWER IN
GREEN	GROUND	GND	GND
BLACK	HOT	NO1/NC1	L1
WHITE	NEUTRAL	NO2/NC2	L2

AC Power Input

The CHEMTROL™ PC is a dual-voltage controller with a voltage selector switch located inside the cabinet on the Power Board (see Figure 8). Before connecting the unit to an external power supply, make sure that the voltage selector switch is set to the proper AC power input: 115 V or 230 V.

CAUTION: Damage resulting from improper voltage selection is not covered by manufacturer warranty.

Grounding (GFI)

A grounding lug is provided on the right side of the cabinet. It is important to connect it to a proper earth ground to prevent dangerous current leakage and electrical shock. Ground Fault Interruption (GFI) protection is also strongly recommended for all installations.

Main Power Interlock

To prevent accidental chemical feeding, the controller and the chemical feeders should always be interlocked - i.e. wired in parallel - with the manual switch for the main pump. This prevents feeding chemicals when there is no water flow in the recirculation line.

Panel Interlock

For safety of operation, a panel interlock switch is mounted inside the cabinet to shut off all internal power when the control panel is open.

DO NOT ATTEMPT TO DEFEAT ITS PURPOSE !!!

PC Boards

The CHEMTROL™ PC uses two PC boards:

- a Mother Board (Figure 7) located behind the front panel contains the software, memories and operating electronics,
- a Power Board (Figure 8) located in the back of the cabinet and containing the power input and the output relays.

The two boards are connected together with a ribbon connector.

The schematics in Figure 7 and Figure 8 show the location of the key components. In addition, the components are also labeled on the PC boards themselves.

The PC boards are protected with a 1 A fuse located on the Power board. It is mounted on the upper right of the Power Board and marked F2. If the fuse has to be replaced, make sure to use a 1 A fuse only. The use of a larger fuse may cause irreparable damage to the electronic boards.

Power Board

The Power Board (Figure 8) is mounted on the back panel of the controller cabinet. As shown on the schematic, it contains all the high voltage (115 or 230 V) circuits and components for inputs and outputs.

115V/230V Power Transformer

The CHEMTROL™ PC is equipped with a switchable, dual voltage power transformer that is mounted on the Power Board inside the cabinet.

The voltage selector switch is located near the upper right of the board. Always verify that the switch is set to the correct voltage, either 115 or 230V. Connecting the controller to higher voltage may cause damage to the electronics that is not covered by the manufacturer's warranty.

Relay Jumpers (PC6000)

The PC6000 and PC3000 use two jumpers (J1 and J2) on the Power Board (Figure 8) to determine the connections for five of the output relays. These jumpers are normally set at the factory and should only be changed by a Qualified CHEMTROL™ dealer.

The pin connector must be set to **Filter** for both PC6000 and PC3000 controllers.

The **TDS** connection is used for CT6000 and CT3000 cooling tower controllers.

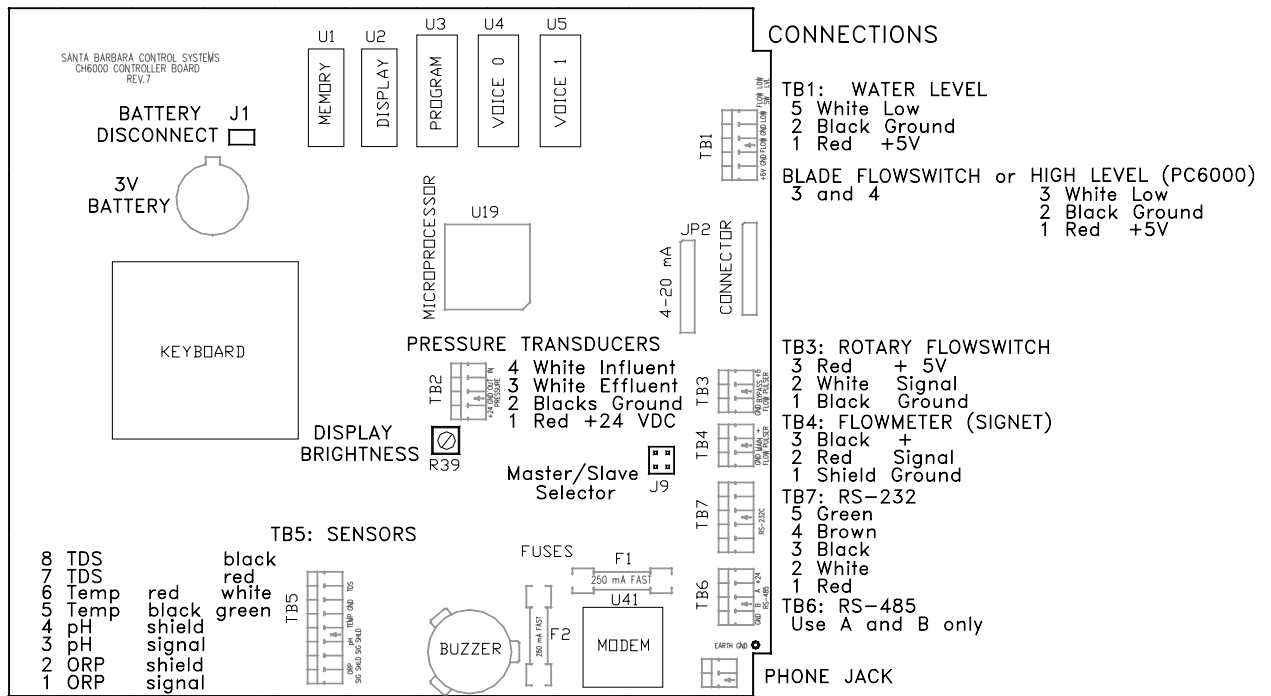

Figure 7 - Mother Board

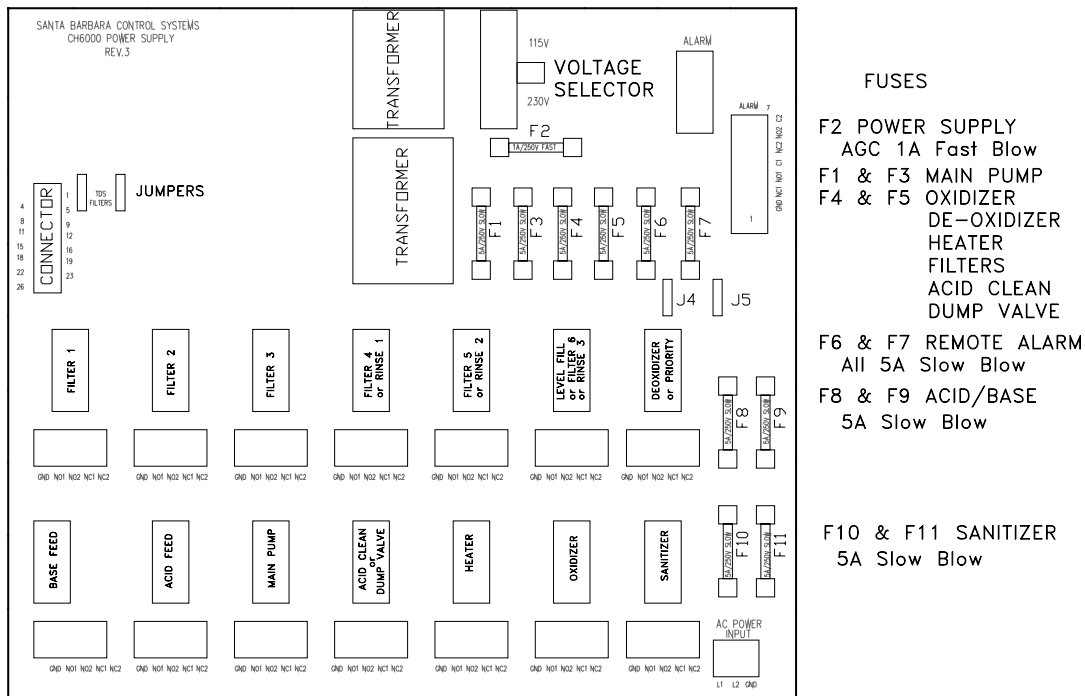

Figure 8 - Power Board

Relays and Fuses

NOTE: *The fuses for the Power Supply to each PC board are AGC-1 Fast Blow. The two modem fuses are 250 mA Fast Blow.*

All other fuses for relay outputs are 5A Slow Blow. All output relays are fused on the Normally Open (NO) and Normally Closed (NC) sides. Both the Hot and the Neutral sides are fused with 5A Slow Blow fuses.

Make sure not to overload the relays. Chemical feed pumps normally draw less than 5A. If a pump draws more than 5A, it will need a motor starter or a magnetic switch.

NOTE: Not all relays may be included on the Power Board, depending on specified options.

Remote Alarm

The remote alarm is a 5A DPDT relay located on the upper right corner of the Power Board. The remote alarm relay can be set for dry or hot contacts, or for any external signal.

To avoid damaging the Power Board, make sure to use the right type of contacts. Call your dealer or the factory if you are not sure.

With hot contacts, the controller powers the alarm with 110 or 230V, depending on the setting of the input voltage of the controller (see preceding page). Connect the leads to the alarm to the Normally Open contacts (NO1 and NO2) on the terminal strip located next to the alarm relay.

With dry contacts, remove the two shunts from J4/J5 located just below the fuses marked F7 and F8. Wire the remote alarm to NO1 and C1.

For an external power source, wire the input power to the terminals marked NC1 and NC2. Wire the remote alarm to the normally open contact (NO1 and NO2). The alarm voltage will be the same as the external power source.

Mother Board

The Mother Board (Figure 7) is mounted directly behind the face panel of the controller and contains all the low voltage circuitry including the microprocessor and program chips, the LCD display and the keyboard pad. It is also used to connect all the sensor inputs.

The key electronic components are the microprocessor and the programmable chips for Program, Display and Memory. The program chips are located in the center at the very top of the board. They can be replaced for upgrading of the software program, which should be done only by an experienced technician.

Sensor Connections

All sensor connections are on the Terminal Barrier strips on the Mother Board, as shown on Figure 7. The pH and ORP sensors are connected externally to the bulkhead BNC connectors on the left side of the cabinet.

The temperature sensor has two leads, black and red. The combined conductivity/temperature sensor has four leads: white, green, red and black. Connect all leads as shown on the Mother Board schematic (Figure 7).

The color coding for the connections are as follows.

TB1 - Level control sensor and blade-type flow switch (PC3) or high alarm sensor (PC6)

5 = Low	White wire from level sensor
4 = Ground	
3 = Flow switch	NO f/s wire or white wire high alarm
2 = Ground	Black wires
1 = +5vdc	Red wires from level sensors

TB2 - Pressure transducer

4 = In	White wire from influent transducer
3 = Out	White wire from effluent transducer
2 = Ground	Black wire
1 = 24vdc	Red wire from transducers

TB3 - Bypass line flow pulser

3 = +5VDC	Red wire
2 = Signal	White wire
1 = Ground	Black wire

TB4 - Main flow pulser (Signet)

3 = +	Black
2 = Signal	Red
1 = Ground	Shield

TB5 - Temp & TDS, pH, ORP

8 = TDS	Black	
7 = TDS	Red	
6 = Temperature	White	Red
5 = Temperature	Green	Black
4 = pH	Shield	
3 = pH	Signal	
2 = ORP	Shield	
1 = ORP	Signal	

TB6 - RS-485 Communications

Connect to A and B only, for multiple serial installations, using Host/Slave configurations (see Remote Communications below).

TB7 - RS-232 Communications

5 = Green
4 = Brown
3 = Black
2 = White
1 = Red

Buzzer

The buzzer is located near the bottom of the Mother Board, as shown on Figure 7. It can be turned on for specific alarm conditions through the software program or for all alarms using the Audio Alarm Submenu 8.2.1 (see page 25).

Display Brightness

The brightness of the display can be adjusted with the potentiometer marked R-39 that is located in the center of the Mother Board (Figure 7).

Backup Battery

The 3V Backup Battery is located on the left side of the Mother Board (Figure 7). It is used to maintain the memory settings in case of loss of AC power. This battery is designed to last for several years in normal operation.

Under normal conditions, the controller will operate without battery power. However, the clock and other memory settings will have to be restored in case of complete power shutdown. Replace the battery if the voltage falls below 2.6 V. The voltage is displayed in Configuration Menu / Battery Submenu.

Remote Communications

Several Remote Communications options are available for the CHEMTROL™ PC controllers:

Option REM uses modem-to-modem communication between the remote computer and the on-board data modem connected to a standard US-type, 6-position RJ12 phone jack located on the bottom right hand side of the Mother Board (Figure 7). If possible, connect the controller to an analog outside telephone line dedicated for remote operation. If the line is also used for voice communications, users should wait for at least three rings to allow the modem to answer a call.

The modem is a combination Data/Fax/Voice multimedia device registered by the Federal Communications Commission (FCC), Number B46USA-22429-MN-E.

MODEM SPECIFICATIONS	
FCC Registration Number B46USA-22429-MN-E	Ring Equivalency Number (REN) 0.2 A

The Ring Equivalency Number (REN) is 0.2 A. Most telephone companies require that the sum of all devices connected to a telephone line do not exceed 5. If a problem arises as a result of operating this equipment, you may have to provide information about this modem to the Phone Company or to the FCC. If the equipment causes disruption to the telephone network, the Phone Company may disconnect your service.

Option ETHCOM uses Ethernet / Internet communication between the remote computer and the on-board Ethernet modem. Connect the controller RS485 A & B ports to the Black and Red wires of the cable provided with the Ethernet modem. Set the controller as a slave by orienting the jumper J9 as marked on the motherboard (Figure 7). Then, connect the Ethernet modem to the TCP/IP network via its standard RJ45 TCP/IP jack.

Option RS485 establishes a direct connection between one on-site computer and the controller through a dedicated pair of wires (3,000 feet maximum). Connect the controller RS485 A & B ports to the computer RS485/RS232 converter. Set the controller as a slave by orienting the jumper J9 as marked on the motherboard (Figure 7).

Multiple Serial Connections

Up to thirty (30) CHEMTROL™ PC controllers can be multiplexed to a single phone line, a single Ethernet address,

or a single computer line by using a network consisting of a host and several slaves. The connections are made through the controllers RS485 Ports.

Different models of CHEMTROL™ PC controllers can be mixed and matched in a network. Each controller is identified by its own ID number. This number is set up through software in the Communications Submenu 8.3.1 (see page 28).

The host controller needs one of the three remote communication options described above (REM, ETHCOM or RS485).

The slave units need only an RS485 connection (Option MULTI) and an internal ID number. The slave units must be located within 3,000 feet of the host controller and connected with two Category 5 wires (one pair). The RS485 terminal has four terminals, only two of which, marked A and B, are used. Each unit must be wired A to A and B to B for proper communications. The slave units can be connected directly to the host unit or through any other slave units.

Any controller can be set up at any time as either host or slave by orienting the jumper J9 as marked on the motherboard (Figure 7).

CAUTION: Do not wire the connections marked 24 VDC or GND on the RS485 terminal. This could cause serious damage to the terminal.

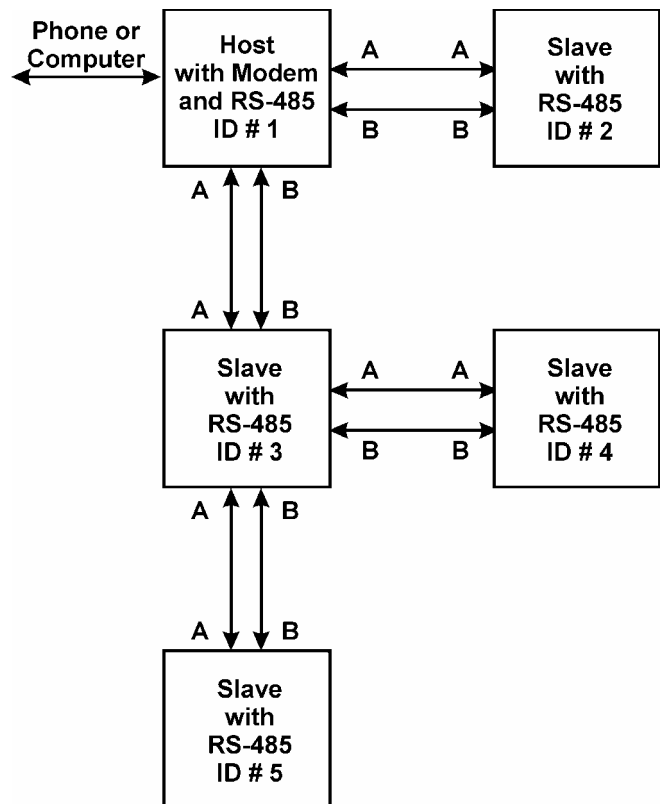

Figure 9 - Multiplex Connections

4-20 mA Converter Boards

The 4-20 mA Converter Boards are two optional piggyback boards. They convert the digital outputs of the controller (sensor or control outputs) into analog signals that can be used by analog monitoring and control equipment.

The two boards are identical and are normally installed at the factory on the motherboard before shipping, as shown in (Figure 10). The location on the motherboard determines the function, i.e. sensor signal or control outputs. Either one of the boards or both can be installed, depending on requirements.

If the boards are installed properly, the controller software automatically shows the 4-20 mA menu line in the Submenu 8.3 - Communications.

Field Installation

For field installation, turn off all power to the controller. Position the converter board on top of the motherboard as shown on Figure 10. Press the electrical connector J21 into the socket of the motherboard marked JP1 (or JP2 depending on option) and the three plastic standoff fittings into the three corresponding holes on the motherboard.

4-20 mA Connections

Figure 11 shows the connections for each Converter Board. Determine the type of signal required by the host system. There are two types of signals used in 4-20mA communications, Internal source or external sink. Each communication channel has four sets of jumpers that must be shunted to the proper setting. (Please note that the factory settings are generally for internal source).

The 4-20mA output signals from the board are located on the terminal boards marked TB1 and TB2. Each channel has a + and - indication corresponding to the markings on the board.

The 4-20mA Signal Board has five communication channels for pH, ORP, TDS, temperature and PPM readouts. Each analog signal requires two wires for connection to the central monitoring system.

The 4-20mA Control Board also has five pump control channels for acid, sanitizer, oxidizer, deoxidizer and base feed. Each analog control signal requires two wires for connection to the corresponding pump.

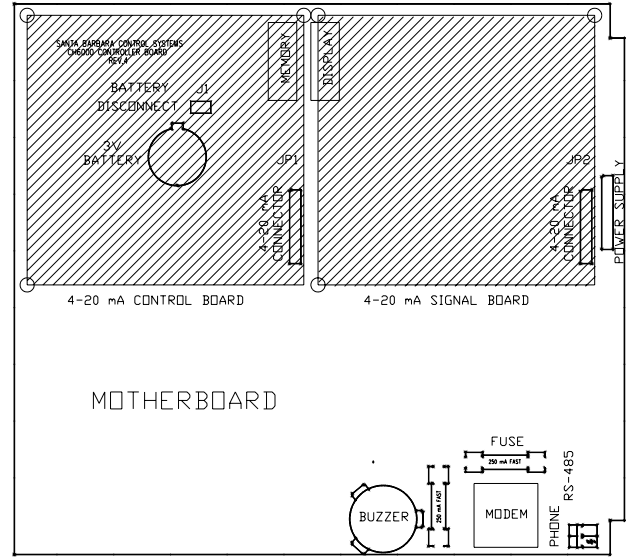

Figure 10 - Installation of 4-20 mA Boards

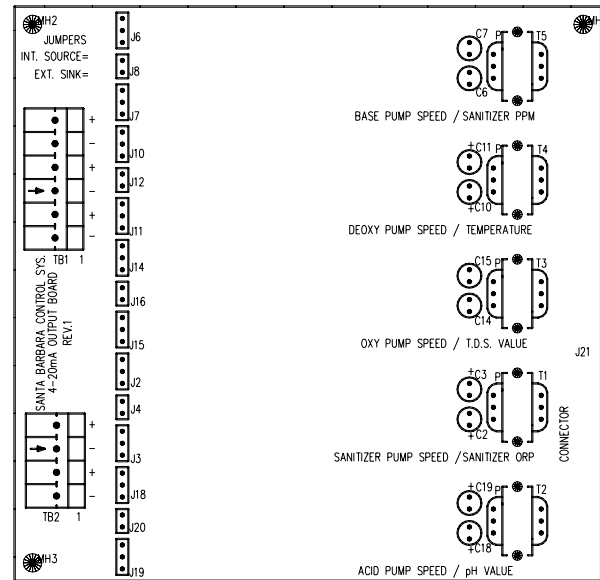

Figure 11 - 4-20 mA Converter Board

PLUMBING

This section covers the installation of the sensors and the connection of the chemical feeders or control valves.

All chemical injection should be done on the return line, i.e. downstream of the sensors and pool equipment, as explained in the Chemical Feeders section.

Installation of Sensors

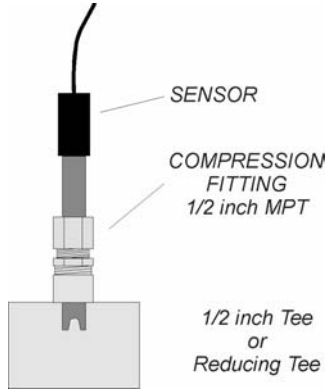

Figure 12 - Sensor Installation

The CHEMTROL™ PC controller uses up to eight different sensors for measurement of water chemistry, temperature, flow rate, pressure and water level:

- potentiometric sensors for pH and ORP,
- thermistor for temperature,
- conductivity sensor for Total Dissolved Solids,
- Hall effect pulse generator for flow rate,
- piezoelectric sensors for influent and effluent pressures,
- electro-optical water level sensor.

The first four sensors measure water chemistry (ORP, pH, conductivity and temperature). These can be mounted directly on a 2-inch main recirculation line using PVC reducing tees Figure 12). On larger diameter lines, they must be mounted on a 1/2-inch bypass line - using either a Bypass Line Assembly (Figure 13) or a Sensor Cell Cabinet (Figure 15).

In-line Installation (2" Pipe)

On smaller installations (2 " pipe diameter), the sensors can be mounted directly on the main recirculation line between the strainer and the pump (Figure 12).

Use only 2x2x1/2 in. SST reducing tees without reducers. Do not install the sensors near an elbow or a constriction where there might be excessive turbulence.

Install the tees on the suction side of the pump and make sure that the tip of the sensor is oriented downward - as shown in Figure 12 - to avoid formation of air pockets near the tip. The sensors should be readily accessible for servicing but not exposed to physical damage.

After inserting the sensor, be careful not to overtighten the compression fitting as it can crush the small glass tube inside the sensor. Make it finger tight (no wrench).

Bypass Line Installation

The CHEMTROL™ Bypass Line Assembly (P/N BPL not assembled) shown in Figure 13 is designed to facilitate the installation of the potentiometric sensors and to assure a smooth and steady flow of water by the sensors. It includes:

- two (2) compression gland fittings (1/2" MPT),
- two (2) PVC tees (1/2" SST),
- one (1) in-line Y-filter (3/4" MPT),
- one (1) in-line flowmeter (1/2" FPT),
- a rotary safety flow switch (1/2" FPT),
- two (2) ball valves (1/2" SxS) for flow adjustment and for isolating the bypass line during backwashing of the filter and other maintenance operations,
- one (1) ball valve (1/2" SxS) for water sampling and testing.

The Bypass Line Assembly should be installed exactly as shown on Figure 13. In particular, make sure to install the flowmeter in a vertical position and to install the flow switch downstream of (after) the sensors to assure a smooth flow of water near the sensors.

Figure 13 - Bypass Line assembly

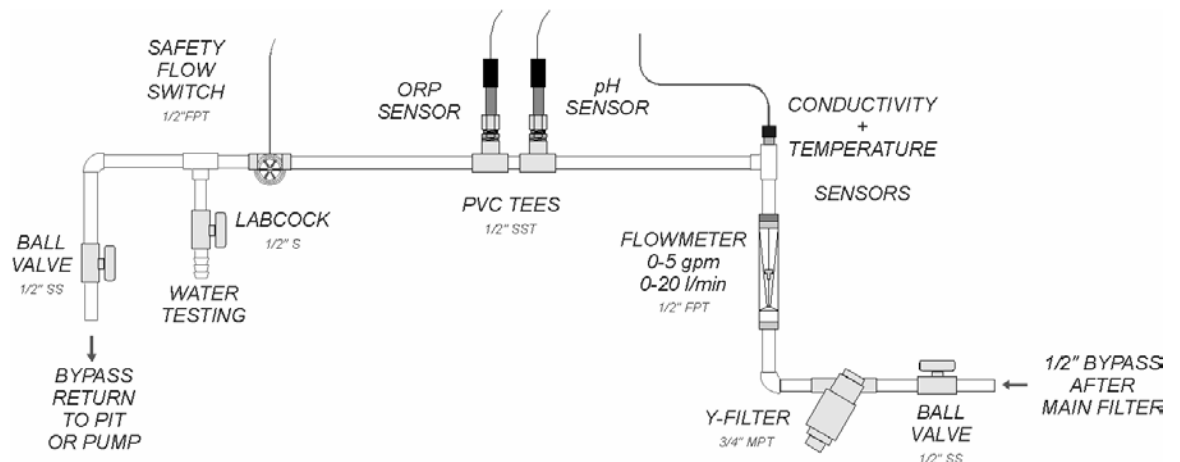

Flow Cell Assembly (Option)

For ease of installation and maintenance, the sensors can be mounted on an optional Flow Cell Assembly, as shown in Figure 14. It includes a sensor cell with an air vent and a clear cover, two compression fittings for the ORP and pH sensors, a water sampling tap and two ball valves for controlling the water flow in and out.

Sensor Cell Cabinet (Option)

For even greater ease of installation and maintenance, the components of the bypass line assembly can be supplied in a pre-plumbed Sensor Cell Cabinet (also called Wet Box). The Flow Cell Assembly is mounted in a fiberglass cabinet containing the sensor cell assembly. Also included is a Y-filter, a flowmeter and a paddle wheel safety flow switch. Install on a 1/2" bypass line, as shown in Figure 15.

Make sure that the Sensor Cell Cabinet is located within 2' (60 cm) of the controller cabinet or order sensor extension cables (see Sensor Cables). See wiring instructions in the ELECTRICAL section and operational instructions under WATER FLOW below.

Water Flow

Proper flow of water past the sensors is essential to obtaining good readings. To check the water flow in the bypass line, start the main recirculation pump. Open both the intake and the return valves on the bypass line and read the flow rate on the flowmeter. It should be in the middle of the range, i.e. about 2-3 gpm (about 8 to 12 l/min). If the water flow is too high, reduce it by closing down the valve on the RETURN SIDE of the bypass line. If there is no water flow, replumb the bypass line as shown on the schematic.

NOTE: The most common installation problems with bypass line or wet box installations are caused by faulty hydraulics.

To ensure proper water flow, make sure that the bypass line is properly connected. The intake side should be off the pressure side of the recirculation system, i.e. after the filter. The return side should be to a low-pressure area - such as the vacuum side before the recirculation pump, or downstream after the heater, or atmospheric pressure in the pit of a vacuum sand filter or balancing tank.

Paddle Wheel Rotary Flow Switch

The Rotary Flow Switch is a safety switch for the bypass line.

The switch contains a transducer that generates an electrical signal proportional to the water flow. The relay trip point is factory adjusted for a minimum flow rate of 1 gpm (about 4 l/min). (Make sure to use the flow restrictor included in package).

CAUTION: *Improper wiring will result in switch burnout (not covered under warranty).*

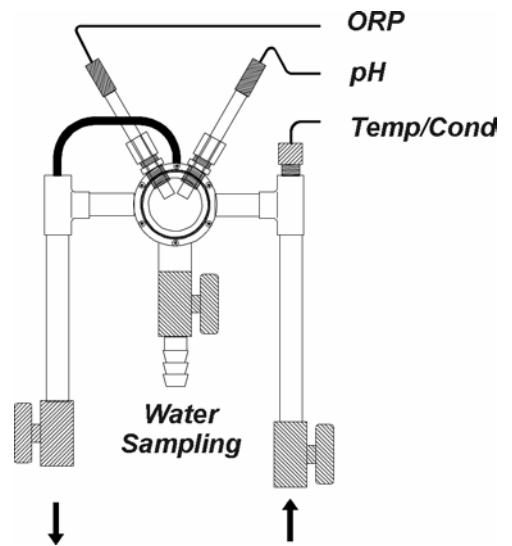

Figure 14 - Flow cell Assembly (Option)

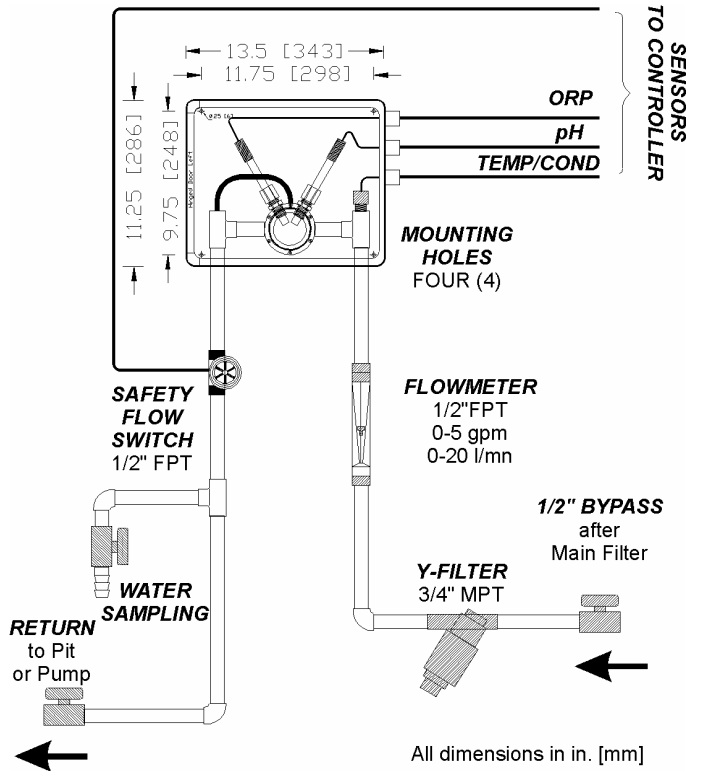

Figure 15 - Sensor Cell Cabinet (Option)

The black, red and white leads should be connected to the contacts marked "BYPASS FLOW PULSER" on the terminal board marked TB3 on the right side of the Mother Board (Figure 7), as indicated:

BLACK	Ground
WHITE	Signal
RED	+ 5VDC or +24 VDC

WATER CHEMISTRY SENSORS

Sensor Properties

The ORP and pH sensors are non-corroding sealed combination electrodes (Figure 16). They do not require refilling. Each sensor has an external plastic body and an inner glass tube that can be broken if stressed too severely.

The potentiometric sensors produce small voltages - in the millivolts range. Since they have a high impedance (20 to 50 megohms), the electrical current produced by the sensors is extremely small - in the picoamp (10^{-9} A) range. The output is so small that it cannot be measured with ordinary voltmeters and must be internally amplified by the controller.

There is no electrical current flowing from the controller to the sensors and the sensors are optically isolated from the high voltage circuit inside the electronic module. Therefore, they create no electrical danger.

ORP Sensor

The ORP (Oxidation-Reduction Potential or Redox) Sensor monitors the activity of the sanitizer (Fast Acting Free Chlorine, Bromine or Ozone) through its oxidizing power. It is recognized by its red color, the wide platinum band at the tip of the electrode and the white plastic tag on the cable.

pH Sensor

The pH Sensor monitors the acidity of the water and works with any acid or base. It is recognized by its blue color and by the glass bulb at the tip.

Sensor Installation

The pH and ORP sensors are shipped in individual cartons for extra protection. When ready for installation, remove the plastic cap on the tip of the sensor. If it is difficult to remove, dip it in water for a few seconds. It should then slide off easily. There may be a white crystalline deposit around the cap. This is produced by the salt solution that is used for shipping. It does not affect the performance of the sensor.

For installation of a sensor, the ½" compression fitting should first be screwed in the PVC Tee (Figure 12).

Teflon tape can be used but it should not be overtightened. The sensor should be carefully inserted through the fitting, as shown on the schematic above, being careful not to bend or overtighten it, to avoid breaking the small glass tube inside. The tip should be about ½" (1 cm) inside the PVC tee. It does not matter which sensor, ORP or pH, is upstream or downstream.

Sensor Cables

The potentiometric sensors are supplied with a standard 10' (3 m)-long cable made of coaxial wire designed to minimize electrical interference. For ease of identification, all ORP cables have a white marker.

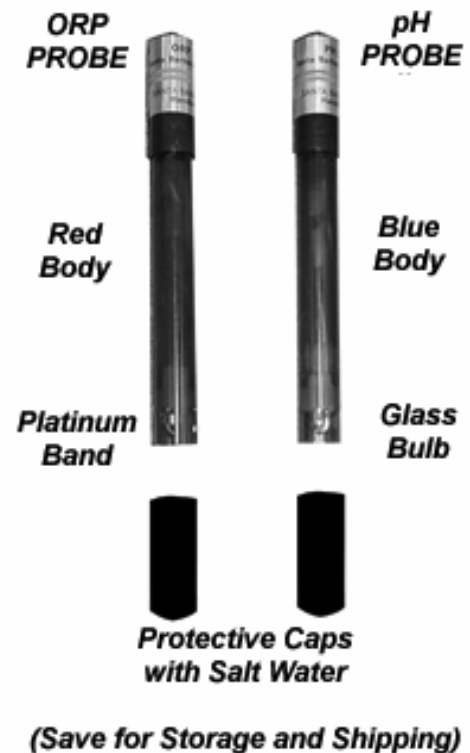

Figure 16 - ORP and pH Sensors

The cables are terminated with bayonet-type, spring-loaded, push-and-twist male BNC connectors. These are connected to the proper female BNC connectors located on the left side of the controller cabinet.

If the cable is longer than needed, it should be coiled neatly and attached under the cabinet. DO NOT ATTEMPT TO CUT THE SENSOR CABLE under any circumstances.

If a longer cable is needed, custom-made extension cables with BNC connectors can be ordered from the factory in lengths of up to 1000 feet. For longer distances, a pre-amplifier may be required. Consult your dealer or the factory for details.

Electrical Interference

The CHEMTROL™ PC controllers feature differential amplification of the sensor signals to reduce electrical interference from stray currents in the water.

Electrolytic chlorine generators are a frequent source of current leakage. This should not be a problem with properly designed commercial-type generators. If using several generators, DO NOT install them in series. Instead, use a manifold and plumb the generators in parallel.

To check for current leakage, compare the readings of the sensors when they are in line and when they are dipped in a plastic bucket containing the same water from the pool or spa. If you get different readings, there is current leakage. Its source must be identified and eliminated with proper grounding by a qualified electrician.

Storage and Winterizing

CAUTION: STORING OR SHIPPING A SENSOR WITHOUT CAP OR WATER WILL VOID ITS WARRANTY.

All ORP and pH sensors are shipped with a plastic cap on the tip to protect the tip from physical damage. This cap also contains water to prevent the sensor from drying out.

Remember to store the protective caps inside the sensor box or inside controller cabinet so that they are available for storage, winterizing or shipping. When storing or returning any sensor for warranty consideration, always add water inside the cap to prevent the sensor from drying out.

Freezing can damage the ORP and pH sensors. They should be removed from the line and stored at room temperature whenever freezing is expected.

Sensor Warranty

The ORP and pH sensors are covered by a standard one-year manufacturer warranty. This does not include damage caused by physical abuse such as breakage of the inner glass tubing or by drying out of the tip. BE CAREFUL IN HANDLING THE SENSORS and ALWAYS REPLACE THE CAP WITH WATER INSIDE when not in use.

In case of sensor failure, return it as soon as possible with its cap on and with water inside the cap for warranty consideration or replacement.

TEMPERATURE SENSOR

If the CONDUCTIVITY option is not included, the Temperature Sensor is supplied separately as a thermistor imbedded inside a 1/4" MPT fitting with a 10-ft (3 m) connecting cable (Figure 17). A 1/4" reducer epoxied to a 1/2" SxS PVC tee is also supplied.

Install the sensor near the ORP and pH sensors, either directly on the main line or on the bypass line (Figure 13), flow cell (Figure 14) or sensor cell cabinet (Figure 15).

Connect the red and black leads to the Terminal Barrier strip TB5 as indicated on the schematic of the Mother Board (Figure 7).

NOTE: When the CONDUCTIVITY option (TDS) is specified, the temperature sensor is incorporated in the conductivity sensor (Figure 18). This simplifies installation, as only one sensor fitting is required.

Figure 17 – Temperature Sensor



CONDUCTIVITY SENSOR

The Conductivity or TDS (Total Dissolved Solids) Sensor consists of two graphite electrodes forming the measuring cell. It also contains a thermistor that is embedded inside the sensor. The sensor is supplied with a 10-ft (3-m) connecting cable and a specially drilled 1/2" MPT PVC fitting, as shown on Figure 18.

Using a 1/2" FPT PVC tee, install the sensor near the ORP and pH sensors, either directly on the main line or in a 90° elbow on the bypass line (Figure 13), flow cell (Figure 14) or sensor cell cabinet (Figure 15). Make sure that the sensor is oriented so that the water flows smoothly through the measuring cell.

The four leads from the conductivity/temperature sensor must be connected to the Terminal block strip TB5 on the Mother Board (Figure 7).



Figure 18 - Conductivity Sensor

FLOW SENSOR

Flow Sensor Location

Always install the flow sensor as far away as possible from obstructions that can affect the flow profile around the sensor.

Figure 19 shows manufacturer guidelines for minimum lengths of straight pipe before and after the sensor. For best results, respect these guidelines as much as possible.

Depending on pipe diameter, three different models of sensors are used for flow monitoring:

- Model 2536-P0 for diameters from 2 to 4 in (50 to 100 mm) (Figure 20),
- Model 2536-P1 for diameters from 5 to 8 in (100 to 200 mm) (Figure 20),
- Model 2540 for lines over 10 in. (250 mm) in diameter (Figure 21).

The rotor shaft should be inserted at least 10% of the pipe diameter into the water. The sensors are paddle wheel-type, Hall effect generators with a true square wave. They are rated at 200 psi (14 bar) at 68°F (20°C). The signal can be transmitted up to 1000 feet (300 m) without distortion.

Follow manufacturer instructions carefully and do not install while the line is under pressure.

Flow Sensor Saddles

Saddle assemblies for flow sensors are available in 2, 4, 6 and 8 in. diameter (see Figure 22 and Figure 6). For larger sizes, call the factory for special order.

Flow Sensor Connections

Connect the three leads from the sensor to the Terminal Barrier strip TB 4 as indicated on the Mother Board Schematic (Figure 7).

CAUTION: A 24 V DC signal is used for signal generation. Reversing the wires may cause damage to the sensor and to the microprocessor.

Enter the **calibration K-factor** in pulses per unit of volume flow (gpm or l/m) for the specific pipe diameter and thickness, as discussed in Chapter IV - Operation (Page 40).

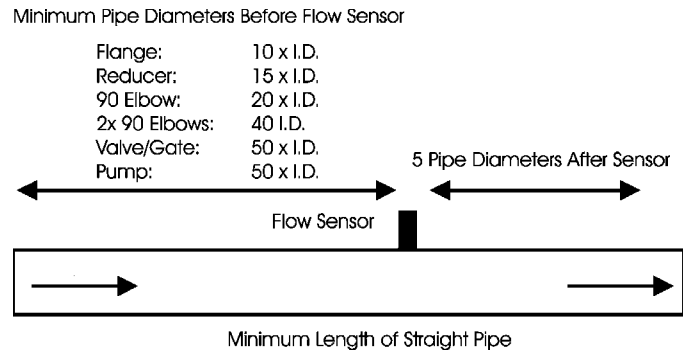

Figure 19 - Flow Sensor Installation



Figure 20 - Model 2536 Flow Sensor



Figure 21 - Model 2540 Flow Sensor



Figure 22 - Saddle for FS2536



Figure 23 - Saddle for FS 2540

PRESSURE TRANSDUCERS

The pressure sensors are CHEMTROL™ Series 1200 transducers (Figure 24) with a 1/4-18 NPT thread connection rated at -15 to 45 psi (-1 to 3 bar).

For differential pressure monitoring, a transducer should be installed on the intake (influent) side of the filter or bank of filters and another one on the return (effluent) side.



Figure 24 - Pressure Transducer



Figure 25 - Optical Level Sensor

Transducer Connections

Connect the leads from the sensors to the Terminal Barrier strip TB2 as indicated on the Mother Board Schematic (Figure 7). For calibration, enter the default factors of 12.0 and 0.75 through the PUMP Submenu 6.2.1.

WATER LEVEL SENSOR

The water level in the pool can be automatically maintained with a fill valve controlled by the water level sensor. The sensor is an ELS-1100 Series electro-optical sensor with a 1/4" NPT thread (

Figure 25). Having no moving parts, it is simpler and more reliable than mechanical systems.

The optical sensor uses the reflection of a laser beam inside a prism to determine the position of the water level (Figure 26). With no liquid present, the light beam from the LED is reflected within the prism to the receiver. When the liquid level reaches the prism, the index of refraction is changed and the beam is cannot be detected by the receiver.

Installation

Locate the sensor in a convenient location in the pool, surge pit or water tank as shown on Figure 27. Wire the fill valve to the Level Fill relay.

Connect the leads from the sensor to the Terminal Barrier strip TB1 as indicated on the Mother Board Schematic (Figure 7).

Maintenance

The surface of the prism should always be kept clean and should be positioned at least 2" (cm) away from reflective surfaces.

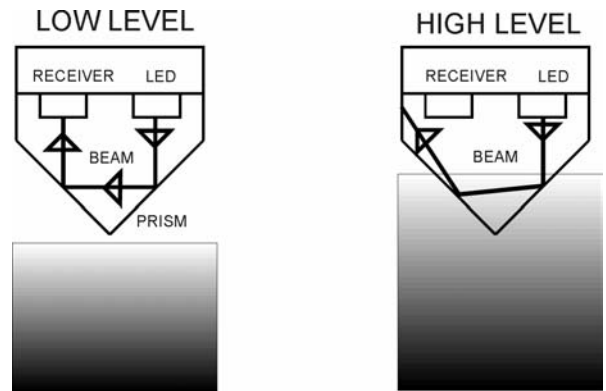
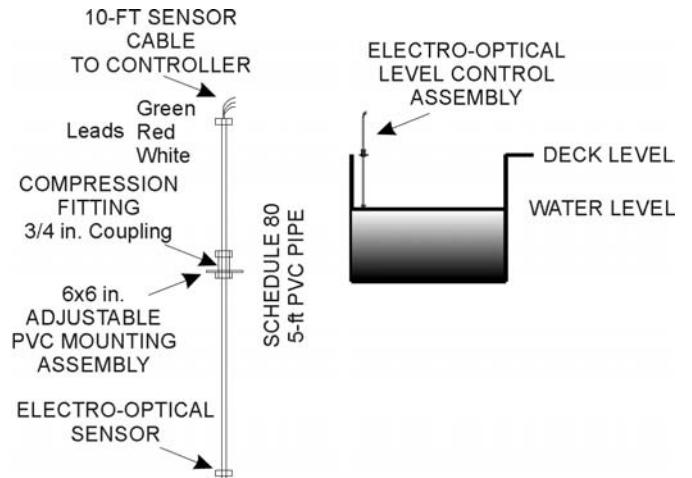

Figure 26 - Optical Beam Path

Figure 27 - Water Level Assembly



CHEMICAL FEEDERS

WARNING: Tank Sizing

The CHEMTROL™ PC controller includes many safeguards to prevent overfeeding of chemicals. However, there is always a risk of physical failure of the electronics or feed equipment that could cause overfeeding of chemicals. To prevent damage or injury to persons, it is imperative to size the chemical tanks so that no dangerous amount of chemicals will be fed in case of equipment failure.

Chemical Feed Pumps

Chemical feed pumps are used to feed liquid sanitizers, such as sodium hypochlorite NaOCl, also known as liquid chlorine, or solutions of calcium hypochlorite or dichlor powder. Liquid chemicals for pH control include muriatic acid, caustic soda or solutions of soda ash.

Any standard chemical feed pumps (diaphragm, piston or peristaltic) approved by NSF (National Sanitation Foundation), UL (Underwriters' Laboratories), ETL (Electrical Test Laboratories), CSA (Canadian Standards Association) or similar national and international organizations, can be used, as long as they are properly sized for the installation.

Install the pumps as shown in Figure 5, following the electrical code and the pump manufacturer's instructions.

Carbonic Acid (CO₂) Valve

A special solenoid valve for carbonic acid can be used to control the addition of CO₂, an acid used to lower pH. It also increases Total Alkalinity making pH control difficult. Add muriatic acid, HCl, to reduce high alkalinity.

Gas Chlorinator

NOTE: Use of Chlorine gas is very dangerous. Make sure to follow all local safety codes.

Gas chlorinators should be installed and maintained only by factory-trained technicians following the instructions of the manufacturer.

If required, the injection line for chlorine gas can be controlled with a specially designed, corrosion-proof solenoid valve installed between the gas chlorinator and a Venturi injector. Alternatively, a magnetic starter can be used to control a booster pump for the chlorinator bypass line.

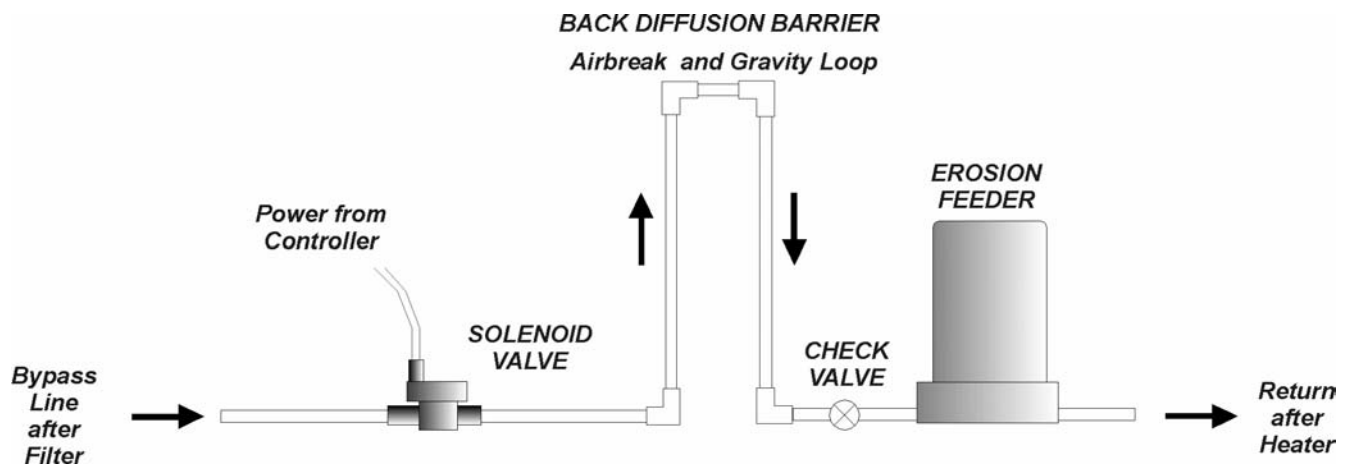

Figure 28 - Erosion Feeder Control

Erosion Feeders

Erosion feeders for bromine, chlorine or calcium hypochlorite tablets can be controlled with a solenoid valve that is mounted on the intake side of the bypass line before the feeder (Figure 28). This allows the controller to modulate the flow of water through the feeder.

For proper valve operation, the pressure differential through the feeder must be at least 15 psi (1 kPa). This may require installation of a pump on the bypass line.

With less corrosive chemicals, such as bromine dihalo or calcium hypochlorite tablets, the solenoid valve can be mounted before the erosion feeder.

Back Diffusion

With corrosive trichloro tablets, it is recommended to protect the solenoid valve with a check valve and an anti-diffusion loop, as shown in Figure 28.

The loop must be narrow to facilitate formation of an air break and tall to maximize the effect of the gravity barrier.

This design reduces – but does not eliminate – corrosive back diffusion. A better idea is to switch to a less aggressive sanitizer.

FILTER BACKWASH

The Power Board (Figure 8) of the CHEMTROL™ PC6000 includes six (6) double-pole, double-throw (DPDT) 5A relays for automated filter backwash. They can be used to control solenoid valves, motorized valves, hydraulic valves or pneumatic valves.

Main Pump Shutoff

To relieve pressure on the backwash valves, it may be desirable to shut off the main recirculation pump during opening and closing of the valves.

Use Filter Submenu 7.8 in the CHEMTROL™ PC6000 to specify if the main recirculation pump is to be shutoff during cycling of the valves. The standard shutoff value is 5 seconds.

Single Filter Backwash

As shown in Figure 29, backwashing of a single filter is controlled with four valves that are connected to the Normally Open (NO) and Normally Closed (NC) poles of Filter Relay 1.

Valves # 1 and #4 are connected to the Normally Open connectors on Relay #1 (marked NO1 and NO2). These valves are open for filtration and closed for backwash.

Valves # 2 and #3 are connected to the Normally Closed connectors on Relay #1 (marked NC1 and NC2). These valves are closed for filtration and open for backwash.

Multiple Filter Backwash

Figure 30 shows the connections for sequential backwashing of multiple filters with three-way valves connected to Filter Relays 1 to 6. If more than six filters are used, several filters can be banked together.

For filtration, the valves are in the normally open position and connect the influent and effluent lines through each filter. In backwash operation (normally closed), the valve is connected to the waste discharge line.

A partial closure valve (priority valve or flow control valve) can be connected to the relay marked De-oxidizer. Specify in Submenu 7.6 if it is to be activated during backwash.

Backwash Stager

Multiple filter backwash can also be done with a backwash stager, a mechanical port selector for multiple filters that can be used in place of solenoid valves.

The stager is operated through a dry contact relay connected to Filter Relay #1 on the Power Board.

CHEMTROL™ PC6000 FILTER BACKWASH

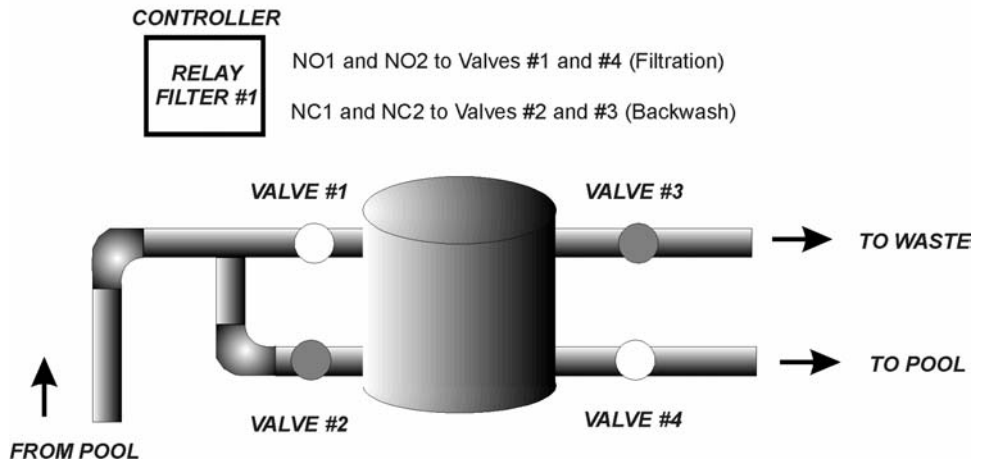

Figure 29 - Single Filter Backwash

Electrical Valves

Solenoid or motorized valves can be connected directly to the NO and NC sides of the filter relays if they draw less than 5 A. If more than 5 A, an intermediate relay of sufficient amperage should be installed.

Hydraulic Valves

Water pressure for a hydraulic valve can be controlled with a three-way piston valve, one port being used to apply water pressure for backwash and one port open to the atmosphere to relieve the pressure on termination.

For EPD or STARK filters, use an ASCO 3-way Solenoid Valve P/N 8221G2, Normally Closed - or equivalent.

Pneumatic Valves

Air pressure to pneumatic valves can be controlled with a standard two-way solenoid valve installed on the air line.

For MIAMI TANK filters, use an ASCO Solenoid Valve P/N 8210G94, Normally Closed - or equivalent.

Figure 30 - Multiple Filter Backwash

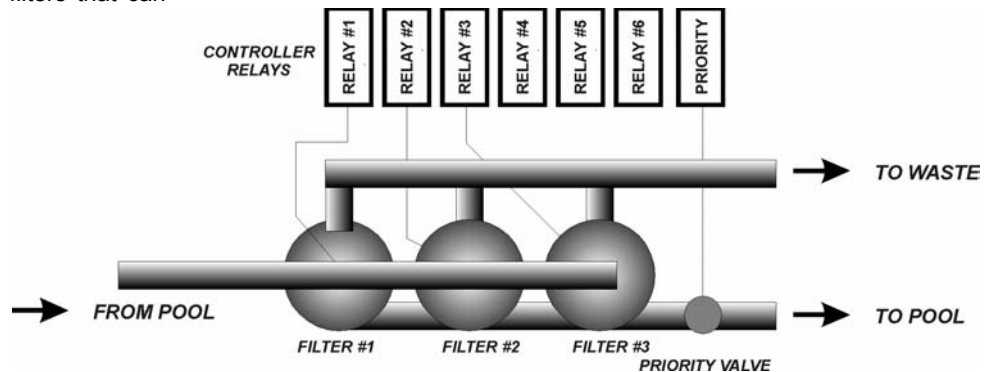

CHAPTER III - STARTUP

CONTROLLER STARTUP

Initial Reset

Before powering up the controller, locate the Battery Jumper J1 on the Mother Board (Figure 7). Remove it, wait one minute and reinstall it. This clears up any unwanted changes in the program and resets the original default values.

With the front door open, verify that the CPU Fail Light on the microprocessor turns ON when power is applied to the unit and turns OFF when the program is running.

Configuration Menu

Upon startup, verify the initial setup through the CONFIGURATION Menu 8.1 (see page 22) and adjust the values as required. This includes adjusting the clock for different time zones and selecting the proper language and units system.

Alarm Buzzer

The Audible Alarm option is normally turned off until the sensors are installed. Use Submenu 8.2.1 (page 25) to turn it on for normal operation.

Bypass Line

By default, the Bypass Line Option is factory-set to YES to prevent accidental feeding when there is no water flow in the bypass line. To turn it off, set the Option to "NO" in Submenu 8.2.2 (page 25).

Battery Check

Check the condition of the Backup Battery. It prevents the loss of memory data in case of power shutdown. The voltage of the battery can be verified through the CONFIGURATION/BATTERY Submenu 8.2.6 (page 27).

If the battery voltage is less than 2.5V, the battery should be replaced with a 3V-lithium battery, Panasonic CR2330 or equivalent.

CHEMICAL CONTROL

Initial Activation of Sensors

For a new pool or spa, it is recommended to wait for a week or two after filtration is started before installing the sensors. This will prevent damage to the sensors until all the dirt and debris have been filtered out of the water. When ready to start the CHEMTROL™ PC, install the sensors in the recirculation line and run the recirculation pump for 30 to 60 minutes or until the readings of the sensors stabilize.

Bypass Line Test

If there is a bypass line, open the sampling tap on the bypass line and adjust the two shutoff valves until there is a smooth flow of water coming out of the tap (no suction or excessive pressure).

Water Chemistry Adjustment

Before starting automatic control, the water chemistry should be adjusted to near the recommended values of 7.5 for pH and about 1 ppm for chlorine (2 ppm for bromine). The chemicals can be added manually or with the controller set on Manual Mode.

NOTE: *The controller will not operate in the Automatic Mode if the sensor readings are below or above the alarm settings.*

Also, verify that the cyanuric acid level is below 40 ppm, the Alkalinity between 80-120 ppm and the Total Dissolved Solids (TDS) level below 1,500 ppm. If either one of these limits is exceeded, the water is contaminated. It should be replaced with as much fresh water as needed.

Water Sampling

Proper water sampling is essential for accurate calibration of the pH and ORP sensors. The preferred method is to sample the water as close as possible to the location of the sensors, usually on the bypass line. The bypass line should be therefore equipped with a water-sampling tap, which can be a ball valve.

Because of the instability of chlorine, particularly under sunlight, samples taken near the surface of the water can give false results.

pH Calibration

NOTE: Always calibrate the pH sensor first, before the sanitizer.

Test the pH of the water at least twice with a fresh solution of a standard Phenol Red test kit, or until you get consistent readings.

The pH of the water should be near 7.4 to 7.5. If not, adjust it manually or with manual feed control:

If the pH is below 7.0:

CAUTION: CORROSIVE CONDITION. Add a base (Soda Ash, Caustic Soda NaOH, pH PLUS, pH UP, etc.) to raise it as soon as possible.

If the pH is above 8.0:

CAUTION: SCALING CONDITION. Add an acid (Muriatic Acid, Hypochloric Acid HCl, Sodium Bisulfate, pH MINUS, pH DOWN, etc.) to lower it.

If the test kit value differs from the value shown on the controller display, select the pH Calibration Submenu 3.2 (see page 33) and enter the value indicated by the test kit, using the 1-Point Calibration option.

For more accurate calibration with two or three points, repeat the same process at two or three different pH values using calibrated standard solutions of appropriate values. Most common values are for pH 4.0, 7.0 and 10.0.

pH Feed (Acid or Base)

The CHEMTROL™ PC has two pH control relays, one for Acid feed and one for Base feed. Acid Feed is activated when the pH is above the setpoint and Base Feed when it is below the setpoint.

In most cases, only one type of chemical is required, i.e. either acid or base, depending mostly on the type of sanitizer used. Make sure to connect the acid or base chemical feeder to the proper outlet on the Power Board (Figure 8).

pH Setpoint

The default value for the pH setpoint is 7.5. It can be modified at any time through the pH Menu.

ORP Calibration

The ORP sensor is direct reading and does not require calibration.

ORP Setpoint

The default value for the ORP setpoint is 700 mV. It can be modified at any time through the ORP Setpoint Submenu 1.3 (page 29).

The controller will automatically activate the chlorinator, brominator or ozonator whenever the reading is below the ORP deadband. It will stop automatically as soon as the reading is above the ORP setpoint.

Sanitizer Calibration

NOTE: *Make sure to adjust the pH between 7.4 to 7.5 before calibration of the sanitizer.*

Test the water with a DPD or FACTS test kit for Free Chlorine or Bromine. Do not use an OTO (Total Chlorine) test kit. Make sure that the test solution is fresh and test at least twice or until you get consistent readings.

The water should test close to 1.5 ppm for chlorine or 3.0 PPM for bromine.

- If the water tests below these values: Add sanitizer as needed to bring the PPM reading to a proper value.
- If the water tests above 3.0 ppm for chlorine or 8.0 ppm for bromine:
 - a. wait until the level is reduced to below these values,
 - b. add a reducing agent (Sodium Thiosulfate), or
 - c. replace part or all of the water.

Select the Sanitizer Calibration Submenu 2.1 (page 31) and enter the value indicated by the test kit.

Time Limits

The Time Limits for each outlet should be set for the length of time that can be safely tolerated for chemical overfeeding - in case of equipment malfunction or operator error. This time limit varies with each installation, based on the size of the installation (gallons of water) and the feed rate of the chemical feeders.

If needed, see your CHEMTROL™ PC Qualified Dealer for assistance.

Shock Treatment

It is recommended to wait several weeks before using the automatic shock treatment cycle, or until all the other operating functions of the controller have been properly tested.

Chemical Saver

The Chemical Saver program is used to lower the oxidizer or sanitizer level when there is little use, such as at night or on weekends.

Chlorination should be prevented completely whenever a pool cover is in place.

It is also recommended to stop sanitizer feed for pools where there is insufficient mixing of water at night - due to the lack of water mixing by swimmers or convection currents. This can lead to stratification of the chemicals in the water and eventual overchlorination.

WATER SATURATION

The CHEMTROL™ PC features automatic calculation of the Langelier Saturation Index Submenu 8.2.3 (page 25).

It is recommended to check the water saturation as soon as possible after installation to prevent damage to the equipment through corrosion or scaling. This should be done immediately after calibration of the pH and temperature sensors, using a reliable test kit to obtain the alkalinity and calcium hardness values.

CHAPTER I V - CONTROLLER OPERATION

Chapter IV describes the menus and submenus used to operate the CHEMTROL™ PC. For an overview, refer to the Menu Tree at the beginning of this manual.

On the right are shown screens for the standard versions of the two models: the PC6000 and the PC3000 (no filter backwash).

The underlines _____ on this screen, and all menus and submenus, show operator adjustable entries, selections and calibrations.

Access

The submenus are accessed by first highlighting a line in the Main Display screen with the UP and DOWN ARROW keys and then pressing the RIGHT ARROW key to enter the submenu. Each menu or submenu is therefore identified by a series of numbers - from 1 to 8 - which correspond to the display lines that are used to access it. For instance, Submenu 8.1.4 for Configuration/Initial Setup/Clock is accessed by scrolling down to and pressing on line 8 on the Main Display Screen, then line 1 on the Configuration Menu and finally line 4 on the Initial Setup Submenu. To return to any previous menu, press the UP ARROW key.

For ease of operation, the Configuration and Setup (Menu 8) is discussed first. The other menus are discussed afterwards in numerical order.

Default Setup

The CHEMTROL™ PC controller is initially loaded with standard default values that allow it to start operating normally. It is therefore not required to initialize it in order to operate the controller, as it defaults automatically to standard setup values, such as "English" language, "U.S. Units", "No password", as well as standard setpoints and alarm values.

The operator can change the original default settings at any time to fit his preferences. If needed, the original default values can also be restored through the Reset Submenu. They will always be automatically restored in case of complete loss of power, including backup battery power.

8 - CONFIGURATION MAIN MENU

As shown on Menu 8, the Configuration Menu is used to view or edit the parameters for Initial Setup, Operations and Communications.

To access the Configuration Menu, use the DOWN ARROW key on the Main Display screen to highlight the time/date line and then press the RIGHT ARROW key to show the next menu. It includes the three submenus shown on the right (Menu 8).

>ORP	<u>650</u>	mV	<u>A</u>
SANITIZER	<u>1</u>	ppm	<u>X</u>
>ACID	<u>7.5</u>	pH	<u>A</u>
COND	<u>2000</u>	uS	<u>X</u>
TEMP	<u>82</u>	F	<u>A</u>
>PUMP	<u>200</u>	gpm	<u>A</u>
FILTER	<u>25 / 20</u>	psi	<u>X</u>
<u>01/31/03</u>	<u>17:00</u>		LSI OK

PC6000 Main Display

>ORP	<u>650</u>	mV	<u>A</u>
SANITIZER	<u>1</u>	ppm	<u>X</u>
>ACID	<u>7.5</u>	pH	<u>A</u>
COND		N.A.	
TEMP	<u>82</u>	F	<u>A</u>
PUMP		N.A.	
FILTER		N.A.	
<u>01/31/03</u>	<u>17:00</u>		LSI OK

PC3000 Main Display

CONFIGURATION
Initial Setup
Operations
Communications

Menu 8

8.1 - INITIAL SETUP SUBMENU

The Initial Setup Submenu is used to specify basic operating conditions of the CHEMTROL™ PC. It is accessed through the Configuration Menu on the last line of the Display Screen.

8.1.1 - Language

The Language Submenu allows the user to select either one of three languages: English, French or Spanish for all displays screens. The standard (default) language is English. Language changes take effect immediately.

8.1.2 - Units

The Units Submenu allows the choice system of U.S. or Metric units to be used throughout the program. The standard (default) value is the U.S. system. The change of units takes place immediately.

Unit equivalencies are as follows:

	U.S.	METRIC
ORP	mV	mV
Sanitizer	ppm	mg/l
pH	pH	pH
Conductivity	μ S	μ S
TDS	ppm	mg/l
Temperature	F	C
Pressure	psi	kPa
Flow Rate	gpm	l/m
Flow	Mga	m3

8.1.3 - Code Number

The Code Number Submenu is used to define different operator access levels. Code numbers may be required for access at key points in the program and for remote communications.

Up to ten Code NUMBERS (of one to five digits each - no letters) may be entered, along with an associated access level from one to three. Make sure to select an easy to remember number, such as a familiar name on a standard telephone keypad.

The following access levels are available:

- Level 1: View only,
- Level 2: Calibration,
- Level 3: All functions.

To clear an existing Code Number, its access level is set to zero.

Once a Code Number has been acknowledged, it remains valid for an hour of continuous operation so that the operator does not have to re-enter it constantly. If necessary, it can be changed by returning to the Welcome screen.

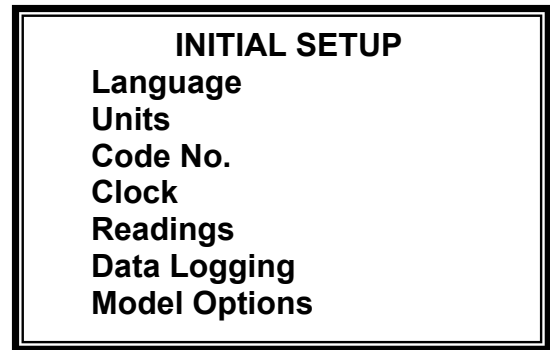

Submenu 8.1

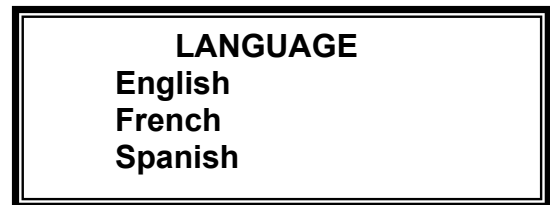

Submenu 8.1.1

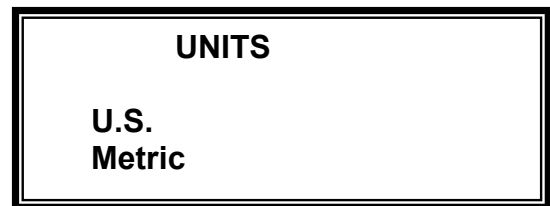

Submenu 8.1.2

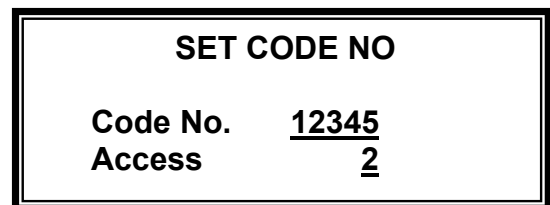

Submenu 8.1.3

8.1.4 - Clock

The clock/calendar is used for programming of daily and weekly schedules. It keeps track of odd months and leap years. In case of power shutdown, the backup battery maintains power to the board. The clock needs to be reset only in case of complete power shutoff with loss of battery power.

The Clock Submenu is used to set the DATE, TIME and DAY of the week.

NOTE: The date display uses the MM/DD/YY (Month/Day/Year) format and the time display, the 24:00 hour format.

8.1.5 - Readings

The DISPLAY HOLD parameter is used to stabilize the readings of the sensors and to eliminate excessive random fluctuations. It specifies the time interval over which the sensor data is averaged before the screen is updated. It can be set between 1 and 60 seconds with a default value of 10 seconds,

8.1.6 - Data Logging

The DATA LOGGING screen selects the time interval for storing test data in the controller memory. Intervals can be between 1 to 999 minutes, with a default value of 60 minutes.

The memory chip can store up to 999 test results. When full, the oldest entries are overwritten by the new ones. Therefore the greater the interval is, the longer it takes to fill the memory. For instance, an interval of 60 minutes (one hour) fills the memory in 41 days. With data logging every four hours, the memory holds 5 ½ months of data.

To avoid losing test data, remember to print it or download it to a computer before the memory is full (see Submenu 8.2.4 - Print Reports). After data download is completed, the Reset function in Submenu 8.1.6 can be used to remove all data and start with a clean slate.

8.1.7 - Model Options

The Model Options Submenu is used to specify the functions that are actually installed on the controller. Non-installed functions should be set to "NO". The Main Display Screen then shows N/A for that function.

For demonstration purposes, it is possible to access any function and review its features - even if it is not actually installed on the controller - by selecting "YES" for that option.

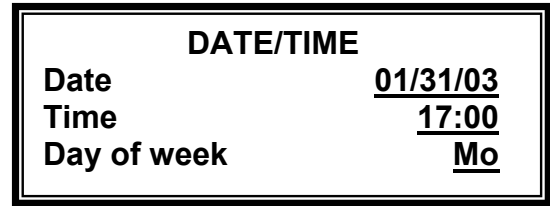

Submenu 8.1.4.

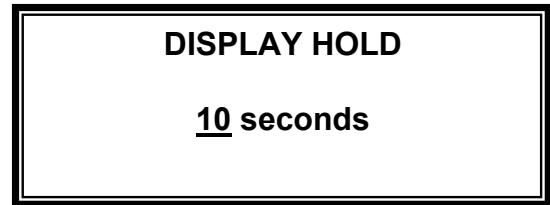

Submenu 8.1.5

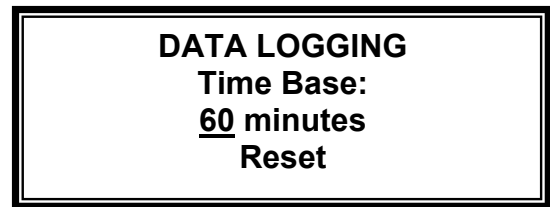

Submenu 8.1.6

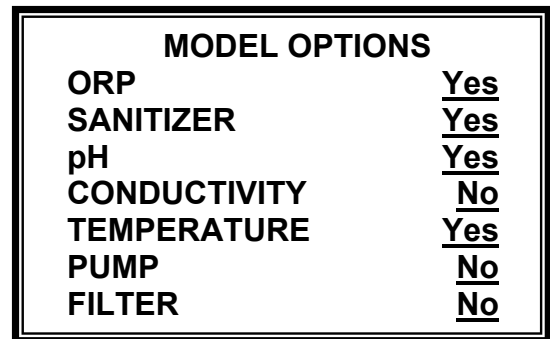

Submenu 8.1.7

8.2 - OPERATIONS SUBMENU

The Operations Submenu allows the operator to access and change operating conditions during normal operation.

8.2.1 - Audio Alarms

This option is used to disconnect the audio alarm (buzzer) and remote alarm in case of out-of-range or other alarm conditions. All visual alarms, such as flashing on the screen, still remain operative. When the DURATION value is set to a value different from zero, the audio alarms are activated for 10 seconds then forced off for the Duration value to create intermittent reminders of alarm.

8.2.2 - Bypass Line

The bypass line is a recommended feature for sensor installation on large recirculation lines, i.e. over 2 inches in diameter. It is included with all PC3000 and PC6000 controllers.

A Safety Flow Switch is used to prevent operation when there is insufficient water flow in the bypass line. This can occur particularly when the bypass line is shut down for maintenance.

The standard flow switch provided with the CHEMTROL™ PC is a rotary flowmeter with a paddle wheel. The shutoff is set at 1 gpm (about 4 l/m).

The Bypass Line Protection option should always be set to YES, indicating that the alarm is active and will cause the interruption of all feed events.

If the flow switch is defective or temporarily disabled, the bypass alarm can be overridden by setting the Bypass option to NO. This override should be used with extreme caution:

WARNING: Feeding chemicals when there is no water running in the bypass line may cause dangerous chemical reactions.

8.2.3 - Langelier Saturation Index

The Langelier Saturation Index is used for monitoring the development of corrosive or scaling tendencies in water. The Saturation Index SI is calculated from the formula:

$$SI = pH + TF + AF + CF - 12.1$$

where:

- pH = pH sensor reading or keyboard input,
- TF = Temperature factor calculated from sensor input or keyboard input,
- AF = Alkalinity factor from data table,
- CF = Calcium Hardness factor from data table.

The microprocessor inside the controller calculates the factors TF, AF and CF directly from the raw data input for temperature (degrees), alkalinity (ppm) and hardness (ppm). The operator therefore does not have to resort complicated conversion tables.

OPERATIONS	
Audio Alarms	<u>YES</u>
Bypass Line	<u>YES</u>
Saturation Index	OK
Print Reports	
Reset	
Battery	
Probe Monitor	<u>YES</u>

Submenu 8.2

ALARM LOCKOUT	
Audio Alarms	<u>YES</u>
Duration (min.)	<u>2</u>

Submenu 8.2.1

SATURATION	
Alkalinity (ppm)	<u>150</u>
Hardness (ppm)	<u>300</u>
pH	<u>7.5</u>
Temperature	<u>80</u>
Limits	
Langelier Index	0.23
Condition	OK

Submenu 8.2.3

LANGELIER LIMITS	
Scaling above	<u>+ 0.3</u>
Corrosive below	<u>- 0.0</u>

Submenu 8.2.3.5

Langelier Limits

The standard limits for the Langelier Index show "OK" between 0 and +0.3, "CORR" if below 0, and "SCALE" above +0.3. If an alarm condition develops, the Display Screen alerts it with flashing characters.

The above values are the generally accepted limits for water saturation. Some experts however, recommend different values, such as -0.3 and +0.3 instead. The limits can therefore be changed by in Submenu 8.2.3. 5.

8.2.4 - Print Reports

The Print Reports Submenu is used to download the test data that has been logged in the internal memory chip of the controller (see Submenu 8.1.6 - Data Logging).

The data is saved in memory in standard ASCII. It can be printed on site or downloaded to a computer using three different methods:

- on-site printing to a serial printer,
- on-site downloading to a computer or laptop,
- remote downloading by modem, Ethernet or Internet to a computer using the CHEMCOM™ program.

After downloading into a computer, the data log can be displayed, edited and printed in text format using a text editor, such as *Windows Notepad*, or *Microsoft Word* as shown in Figure 31.

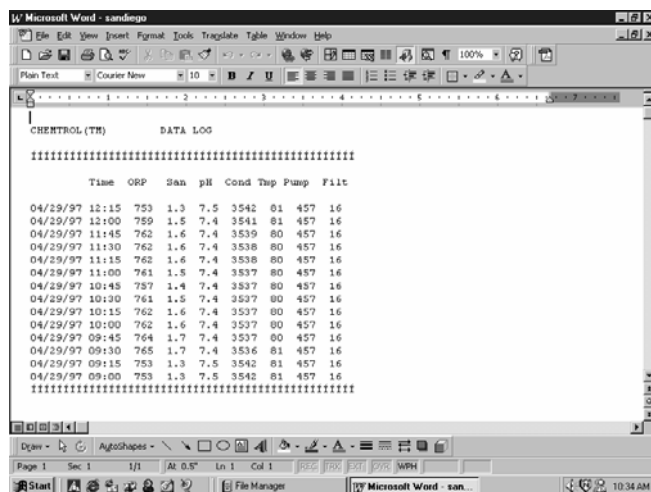

Figure 31 - Data Log

NOTE: In the COMMUNICATIONS Chapter (Page 49), it can be seen that the same data log can be displayed directly through the CHEMCOM™ software program, either as text (Figure 37, page 52) or as graphical display (Figure 38, page 52).

Since a maximum number of 999 sets of test data can be stored in the memory chip, it is recommended to download the data periodically in order not to lose it.

Downloading the data does not erase it from the memory chip. To erase all data in memory, use Submenu 8.1.6 - Data Logging and select Reset.

For printing or downloading, use the desired setup below, then enter Submenu 8.2.4 - Print Reports, select the proper dates, move to Print Data Log and press the RIGHT ARROW. A counter shows the number of tests being printed.

On-Site Printing

For on-site printing, connect a serial printer (usually a thermal printer) to the RS-232 serial outlet on the left side of the controller.

On-Site Download

For direct download to a computer (that is without a modem), you must first set up communication parameters as shown below for DOS or *Windows*. Then connect the serial port on the computer (COM1: or other) to the RS-232 serial outlet on the CHEMCONTROL™ PC, using a null-modem connector, or an adapter available from local electronics stores, or from your CHEMCONTROL™ dealer.

Communication Parameters

The computer communication parameters must be set up as: 1200, 8, n, 1, none. The following setups are shown for DOS and *Windows*, using the serial port COM1 as an example.

DOS Operating System

Use a DOS communications program, such as Procomm Plus or similar. Select Line Port Setup and enter: 1200,N,8,1,COM1. Save the settings with ALT-S.

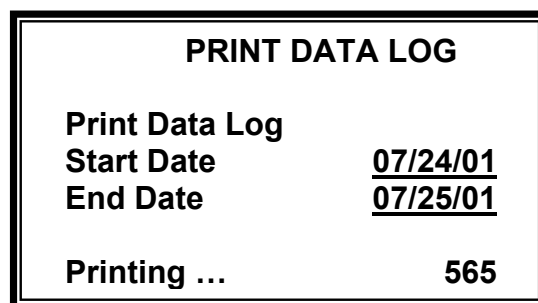

Submenu 8.2.4

Windows 3.1 Download

Click on the icons ACCESSORIES, TERMINAL, SETTINGS, COMMUNICATIONS and select COM1: 1200, 8, None, 1.

Windows 95/98/NT/2000/XP Download

Windows 95/98/NT/2000/XP requires configuration of a HyperTerminal session to be called CHEMCONTROL.

On the Windows desktop, click on the START menu, then PROGRAMS, ACCESSORIES, COMMUNICATIONS and HYPERTERMINAL. Click on the icon marked "Hypertrm", enter the name "CHEMCONTROL" and select one of the icons for identification. On the next window named "Phone Number", click on the bottom line and select "Direct to Com1" and OK. In the next window named "Port Settings", select 1200 bits per second, 8 data bits, parity none, one stop bit, flow control hardware. Click on OK. Select File and Save.

To create the Shortcut for the CHEMCONTROL™ HyperTerminal, click on START, PROGRAMS, ACCESSORIES, and HYPERTERMINAL. Click on the CHEMCONTROL™ icon with the right mouse key, click on "Create a Shortcut" and drag out the icon to the main window. To start the connection click on the CHEMCONTROL™ Shortcut icon, select "Transfer" and "Capture Text".

Remote Download

Logged data can be more easily downloaded by remote computer using the CHEMCOM™ software program for Windows™ (Options REM, ETHCOM or RS485). See the COMMUNICATIONS Chapter (page 49) for details.

8.2.5 - Reset

The Reset Submenu is used to take the calibration parameters back to the initial factory settings. This may be done on initial installation or whenever incorrect parameters have been entered. **Complete Reset** resets all system parameters to their initial "default" settings. **Partial Reset** allows partial resetting of individual functions, such as ORP, Sanitizer, pH, etc.

8.2.6 - Backup Battery

The CHEMTROL™ PC uses a 3 V lithium battery to maintain calibration, setup and test data in memory storage in case of power shutdown. The battery is designed to last for more than 200 days without any power being supplied to the unit. The minimum voltage required is about 2.5 V. The Battery Submenu displays the voltage of the battery for information. A flashing display on the Main Display screen indicates a low battery voltage. To prevent loss of memory data, the battery should be replaced when the voltage gets below 2.5 V.

If power to the memory is completely discontinued, all settings revert automatically to the initial default values. If required, they may have to be individually reset to their proper values by the operator. When changing the battery, it is important to keep power supplied to the unit to keep the proper settings in memory.

8.2.7 - Probe Monitor

Probe monitoring is a **very useful, patented** CHEMTROL™ PC feature (US Patent No. 5,895,565) that allows dynamic monitoring of the ORP and pH sensors to alert a probe failure as soon as it happens.

Other controllers have to wait until there is an out-of-range or alarm condition in order to alert the operator. This could result in serious damage and liability.

To activate or disable the Probe Monitor function, use the RIGHT ARROW to select YES or NO in Submenu 8.2, line 7.

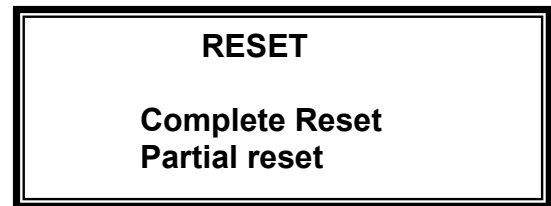

Submenu 8.2.5

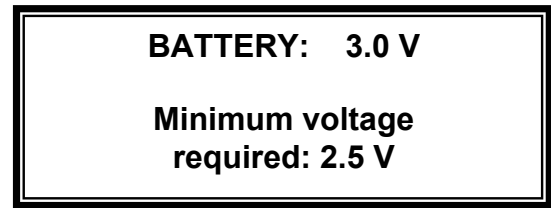

Submenu 8.2.6

8.3 - COMMUNICATIONS SUBMENU

The details of the communications features are discussed in the COMMUNICATIONS Chapter (page 49).

The Communications Submenu is used to select the phone numbers to report alarm conditions and to enter the identification number for voice telephone reporting.

8.3.1 - Phone Numbers

With the option TEL, up to six (6) different phone numbers can be entered for automatic calling in case of an alarm condition. Each number is called sequentially until one of the numbers is answered and the proper password is entered.

To delete a number, replace it with 0.

8.3.2 - Unit Identification

The unit identification number is used to identify individual controllers in multiple unit facilities that are connected to the same phone line. The default value is 1.

It should be set correctly for each controller to be able to be accessed individually in remote multiplex operation.

8.3.3 - Alarm Calling

Select YES if you want the controller to dial automatically the phone numbers listed in Submenu 8.3.1 or NO to disable it.

8.3.4 - 4-20 mA Signal Output

The 4-20 mA output is an option (OPTION 420) to convert sensor readings into analog signals that can be fed into analog monitoring equipment.

The option includes one identical converter board that plugs the mother board of the controller (see Chapter IV - INSTALLATION).

The 4-20 mA Output Submenu is used to set the bottom and top limits for data conversion of each of the functions shown on the screen (Submenus 8.3.4 and 8.3.4.1).

The standard (default) values for the 4-20 mA limits are the values that have been selected for the out-of-range limits. This means that the lower out-of-range limit corresponds to the minimum signal of 4 mA and the higher limit to 20 mA.

To change the limit values of one of the functions, highlight the desired function in Submenu 8.3.4 with the UP or DOWN ARROW key and press the RIGHT ARROW key to access the 4-20 mA LIMITS screen, as shown on the Submenu 8.3.4.1 for ORP.



Submenu 8.3

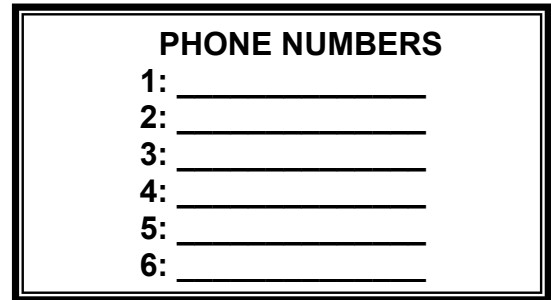

Submenu 8.3.1

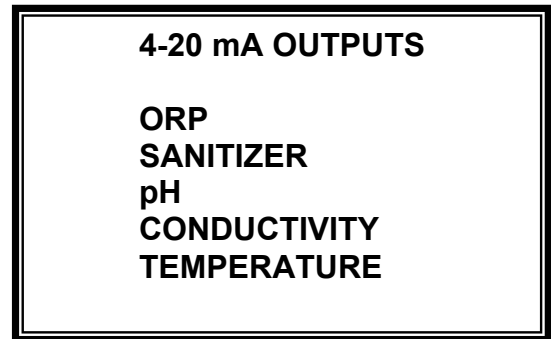

Submenu 8.3.4

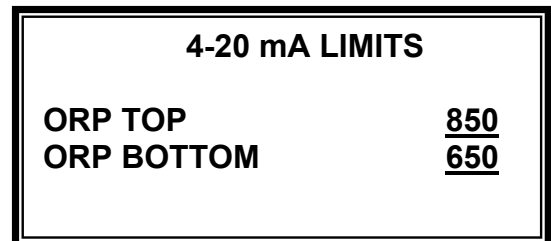

Submenu 8.3.4.1

1 - ORP MENU

Operation

The ORP sensor is used to monitor and control a true oxidizer like ozone, or an oxidizing sanitizer, like chlorine or bromine. In the latter case, the controller monitors and controls the sanitizer through the oxidation-reduction potential it produces in the water.

The ORP Menu screen is used to access all the ORP submenus for Control Mode, setpoint and alarm settings as well as shocking program (superchlorination if using chlorine).

It also displays the actual run time for individual feed events and the cumulative run time since last reset to zero.

1.1 - Control Mode

Line 1 shows the Control mode that is currently selected to control the ORP relay outlet: OFF, Manual, AUTO or Timer.

To change the Control Mode, select the first line with the UP or DOWN ARROW keys and press the RIGHT ARROW key. The Control Mode submenu 1.1 is then displayed.

The selection procedures for control are common to all the control functions. See the CONTROL Submenu further down.

1.2 - Display and Calibration

The second line displays the current reading of the ORP sensor in mV. There is no calibration menu for ORP since there are no readily available calibration solutions in the range of operation for water treatment.

1.3 - Setpoint

The ORP SETPOINT determines the ORP level that the CHEMTROL™ PC maintains automatically when placed in the Automatic control mode.

To change the setpoint, press the RIGHT ARROW key and enter the desired value. After pressing the OK key, the SETPOINT Submenu 1.3 is displayed asking whether the control is to be set for an Oxidizer or a Reducer. Use the UP and DOWN keys to highlight the desired selection. Then press the RIGHT ARROW key to confirm the selection (Oxidizer or Reducer).

The CHEMTROL™ PC includes two relays, one for oxidizer feed and one for reducer (de-oxidizer) feed. The normal (default) setting is for an oxidizer. This means that the oxidizer feed outlet is automatically activated when the sensor reading falls below the setpoint. If set for a reducer, the de-oxidizer outlet is activated when the sensor reading is above the setpoint.

1.4 - Low Alarm

The ALARM LOW value is set to generate an alarm when the ORP reading falls below the set value. To change the value, press the RIGHT ARROW key and enter the numerical value with the digital keypad.

ORP		AUTO
Calibrate	mV	<u>750</u>
Setpoint	mV	<u>700</u>
Alarm Low	mV	<u>650</u>
Alarm High	mV	<u>850</u>
Time Limit	min	<u>30</u>
Run Time	10	125
Last Shock		01/30/03

Menu 1

Off
Manual
Auto
Timer

Submenu 1.1

CALIBRATION
Do not change ORP calibration

Submenu 1.2

SETPOINT
Oxidizer
Reducer
Both

Submenu 1.3

ALARM OPTIONS	
Feed lockout	YES
Alarm buzzer	YES

Submenu 1.4.1

After the alarm value is set, the ALARM OPTIONS Submenu 1.4.1 is displayed, to set the feed interlock and alarm buzzer options. Use the UP and DOWN keys to highlight the desired selection and press the RIGHT ARROW key to change to Yes or No.

Selecting YES for FEED LOCKOUT will inhibit any chemical feed from occurring in case of alarm. Selecting NO will allow feeding to continue. This may be used to continue feeding an oxidizer or sanitizer even if the sensor reading is sometimes low, such as in an overcrowded spa.

Setting ALARM BUZZER to NO disables the buzzer in an alarm condition. There is also a general buzzer shutoff option in the Configuration Menu.

1.5 – High Alarm

The ALARM HIGH value is set to generate an alarm when the ORP reading rises above the set value. After the alarm value is set, the ALARM OPTIONS screen is shown, asking whether a high alarm condition should stop the feeder and activate the alarm buzzer.

1.6 - Time Limit

The TIME LIMIT sets the maximum allowed time (in minutes) for continuous oxidizer feed. This acts as a safety feature to prevent overfeeding in case of malfunction of the chemical feeder or as an alarm if the feed tank runs empty. The standard (default) value for ORP is 15 minutes.

When in alarm, Time Limit is reset by highlighting the value and pressing "OK". To defeat the safety timer, enter zero (0).

1.7 - Run Time

The RUN TIME line displays two separate values: the amount of running time in minutes for each current activation event and the total run time since last reset to zero.

To reset the cumulative runtime, enter zero in the far right column. To reset only the current run time, highlight Time Limit value and press "OK".

The Total Feed Time submenu 1.7.1 is used to show the feed time from a chemical tank since last reset to zero. Knowing the pump feed rate, it can be used to monitor the emptying of the tank and set a low-level alarm. This feature is particularly useful for remote monitoring of the chemical tanks.

1.8 - Last Shock

The LAST SHOCK line shows the last date of Shock Treatment. It is shown for display only, no adjustment can be made to this date.

Press the RIGHT ARROW key to enter the Submenu 1.8 for Shock Treatment, De-shock and Chemical Saver.

1.8.1 - Shock Treatment

Shock Treatment refers to treatment with an elevated level of oxidizer. It should be performed from time to time to prevent the accumulation of noxious chemicals (chloramines) or biological forms (algae, etc.).

Submenu 1.8.1 is used to set the parameters for the shock treatment program. With some chemicals, pH setpoint can temporarily be modified for a period of time before and during shock treatment.

Total Feed Time	
Max (min)	<u>120</u>
Actual (min)	<u>17</u>
Enter 0 for no alarm	

Submenu 1.7.1

SHOCK AND SAVER MENU	
Shock Treatment	
Chemical Saver	

Submenu 1.8

SHOCK	<u>AUTO</u>
Date	<u>02/06/03</u>
Cycle (days)	<u>7</u>
Time ON pH	<u>19:00</u>
Level pH	<u>7.8</u>
Time ON Shock	<u>22:00</u>
Level ORP	<u>850</u>
Time OFF	<u>22:30</u>

Submenu 1.8.1

SAVER	ON	OFF
MO	<u>18:00</u>	<u>06:30</u>
TU	<u>20:00</u>	<u>06:30</u>
WE	<u>20:00</u>	<u>06:30</u>
TH	<u>18:00</u>	<u>06:30</u>
FR	<u>18:00</u>	<u>17:59</u>
SA	<u>18:00</u>	<u>17:59</u>
SU	<u>18:00</u>	<u>06:30</u>

Submenu 1.8.2.1

1.8.2 - Chemical Saver

Submenu 1.8.3 is a weekly program to reduce chemical usage by temporarily modifying the setpoint when the facility is not in use, such as at nighttime or on weekends.

NOTE: For detailed information about shock treatment setup, go to page 48, "SHOCK and SAVINGS SUBMENUS".

2 - SANITIZER MENU

Operation

The SANITIZER function is used to monitor the concentration of chlorine (or bromine) through the oxidation-reduction potential (ORP) that it generates in water.

The SANITIZER Menu screen is used to access the sanitizer submenus for control mode, sensor calibration, setpoint, low and high alarms, and superchlorination.

PPM Readings

The Free Chlorine concentration values are derived from ORP and pH readings - using a proprietary algorithm based on ORP variations in **clean water**. However, the relationship between ORP and PPM can be significantly affected by the presence of organic and inorganic contaminants (including cyanuric acid).

In general, clean water shows higher ORP values at lower ppm values. The dirtier the water gets, the more ppm it takes to generate the same ORP level. This is usually an indication that the water needs shock treatment, or even replacement.

2.1 - Display and Calibration

Line 2 displays the computed SANITIZER concentration in ppm (parts per million) or mg/l (milligrams per liter), as shown on the Main Display screen.

For calibration - as with all other functions - the operator can chose between 1, 2 or 3-point calibration (see CALIBRATION Submenus, page47).

2.1.1 - One-Point Calibration

In most cases, satisfactory PPM calibration can be obtained with one-point calibration, using a DPD (Diethyl-p-phenylene-diamine) test kit for free chlorine. Enter the value obtained with the test kit in submenu 2.1.1, as shown.

2.1.2 - Two-Point Calibration

A special 2-point calibration procedure is available for PPM, as shown on submenus 2.1.2.1 and 2.1.2.2.

NOTE: Before recalibration, always do a partial reset of PPM readings using the Operations Menu 8.2.5.

For a pH of 7.5, the calibration algorithm assumes a baseline default value of 635 mV of ORP for 0 ppm (Submenu 2.1.2.1).

For heavily contaminated water, the baseline can be readjusted to lower values. For instance, if the controller readings are too low by 1 to 2 ppm, a baseline value of 600 mV gives better results. For more than 2 ppm, use 575 mV.

SANITIZER		AUTO
Calibrate	ppm	<u>1.5</u>
Setpoint	ppm	<u>1.5</u>
Alarm Low	ppm	<u>0.3</u>
Alarm High	ppm	<u>3.0</u>
Time Limit	min	<u>30</u>
Run Time		15 60
Last Shock		00/00/00

Menu 2

1-PT CALIBRATION
Enter Measurement
from Test Kit:
1.5 ppm

Submenu 2.1.1

2-PT CALIBRATION
Enter ORP value for
0 PPM and pH=7.5:
600 mV

Submenu 2.1.2.1

Enter PPM measurement
from test kit:
1.5 ppm

Submenu 2.1.2.2

2.3 - Setpoint

The SETPOINT determines the SANITIZER level that will be maintained automatically by the controller when placed in the AUTO control mode.

To change the setpoint, press the RIGHT ARROW key and enter the numerical value with the digital keypad. After pressing the OK key, the SETPOINT TYPE Submenu 2.3 is displayed asking whether the control is for a Sanitizer, or for De-sanitization with a reducer, or for both.

The normal (default) setting is for a sanitizer. This means that the oxidizer feed outlet is automatically activated when the sensor reading falls below the setpoint. When set for a reducer, the reducer relay is activated when the sensor reading is above the setpoint.

2.4 - Low Alarm

The ALARM LOW value is set to generate an alarm when the SANITIZER reading falls below the set value. After the alarm value is set, the ALARM OPTIONS Submenu 2.4.1 is shown, asking whether a low alarm condition should stop the feeder and activate the alarm buzzer.

2.5 - High Alarm

The ALARM HIGH value is set to generate an alarm when the SANITIZER reading rises above the set value. After the alarm value is set, the ALARM OPTIONS Submenu 2.4.1 is shown, asking whether a high alarm condition should stop the feeder and activate the alarm buzzer.

2.6 - Time Limit

The TIME LIMIT sets the maximum amount of time in minutes that is allowed for continuous feeding of the oxidizer to correct a high or low SANITIZER reading. This acts as a safety feature to prevent overfeeding in case of a malfunction of the chemical feeder or as an alarm if the feed tank runs empty.

When in alarm, Time Limit is reset by highlighting the value and pressing "OK". To defeat the safety timer, enter zero (0).

2.7 - Run Time

The RUN TIME displays the amount of running time in minutes for each current activation event and the cumulative run time since last reset to zero.

To reset the cumulative run time, enter zero in the last column. To reset only the current run time highlight Time Limit value and press "OK".

2.8 - Last Shock

The LAST SHOCK line shows the last date of Shock Treatment. It is shown for display only; no adjustments can be made to this date.

If the RIGHT ARROW key is pressed while on this prompt, the screen for Superchlorination, De-shock and Chemical Saver Program will be displayed.

For details on the following options, see the SHOCK and SAVER Submenu further down in Chapter II.

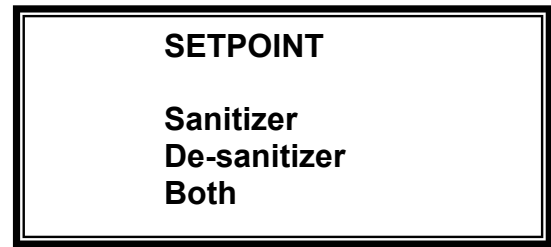

Submenu 2.3

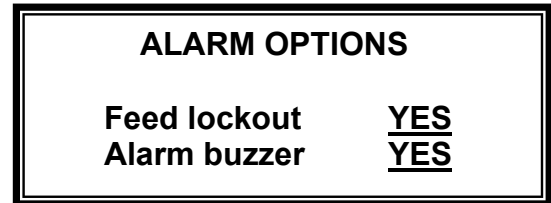

Submenu 2.4

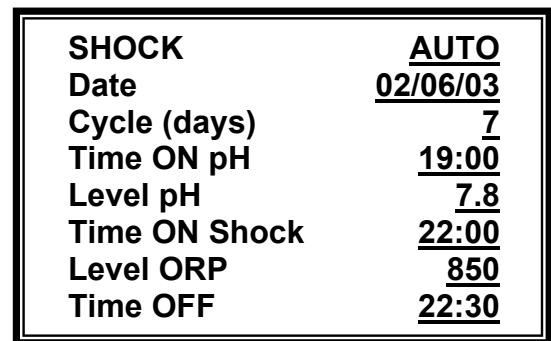

Submenu 2.8.1

2.8.1 – Shock Treatment

Shock Treatment refers to treatment with an elevated level of oxidizer. It should be performed from time to time to prevent the accumulation of noxious chemicals (chloramines) or biological forms (algae, etc.).

Submenu 2.8.1 is used to set the parameters for the shock treatment program. With some chemicals, pH setpoint can temporarily be modified for a period of time before and during shock treatment.

2.8.2 - Chemical Saver

The Chemical Saver program is used to save chemicals by reducing the treatment level when the facility is not used, such as during nighttime or on weekends.

NOTE: For detailed information about shock treatment setup, go to page 48, "SHOCK and SAVINGS SUBMENUS".

3 - pH MENU

Operation

The pH sensor monitors the concentration of acid or base in the water.

The pH Menu screen is used to access all the pH submenus for Control Mode, sensor calibration, setpoint and alarm settings.

It also displays the actual run time for individual feed events and the cumulative run time since last reset to zero.

3.1- Control Mode

Line 1 shows the pH Control mode that is currently selected: OFF, Manual, AUTO or Timer.

To change the Control Mode, select the first line with the UP or DOWN ARROW keys and press the RIGHT ARROW key. The Control Mode Submenu 3.1 is then displayed.

The control mode screen and selection procedures are common to all control functions. See CONTROL Submenus, page 45.

3.2 - Display and Calibration

The second line displays the current reading of the pH sensor in pH units.

The pH sensor is best calibrated by testing the sample solution with a Phenol Red test kit. If needed, the CALIBRATION value may be adjusted to allow for differences or changes in pH sensor readings.

The pH sensor can be calibrated with 1, 2 or 3-Point calibration for origin, slope and curvature. First, press the RIGHT ARROW key to enter the CALIBRATION Submenu. The calibration procedure is common to all control functions. See CALIBRATION Submenu, page 47.

After calibration, the operator is shown the Submenu 3.2.1 asking whether automatic temperature compensation is to be used for pH readings. This option requires the use of the temperature sensor. The correction is normally small near neutral pH and is used only if large temperature fluctuations are expected.

3.3 - Setpoint

The pH SETPOINT determines the pH level that will be maintained automatically by the controller when placed in the AUTO control mode.

To change the setpoint, first press the RIGHT ARROW key and enter the numerical value with the digital keypad. After pressing the OK key, the SETPOINT TYPE Submenu 3.3.1 is displayed asking whether the control is for Acid or Base.

The normal (default) setting is for Acid feed. This means that the acid feed relay is automatically activated when the pH sensor reading rises above the setpoint. When set to base feed, the base relay is activated when the pH reading is below the setpoint.

pH	<u>AUTO</u>
Calibrate	<u>7.4</u>
Setpoint	<u>7.5</u>
Alarm Low	<u>7.0</u>
Alarm High	<u>8.0</u>
Time Limit	min <u>30</u>
Run Time	15 60
Probe Clean	<u>AUTO</u>

Menu 3

Off
Manual
Auto
Timer

Submenu 3.1

Use Automatic Temperature Compensation for pH ? <u>YES</u>

Submenu 3.2.1

SETPOINT
Acid Feed
Base Feed
Both

Submenu 3.3.1

3.4 - Low Alarm

The ALARM LOW value is set to generate an alarm when the pH reading falls below the set value. To change the value, press the RIGHT ARROW key and enter the numerical value with the digital keypad (see ORP submenus).

After the alarm value is set, the ALARM OPTIONS Submenu 1.4.1 is displayed, to set the feed interlock and alarm buzzer options. Use the UP and DOWN keys to highlight the desired line and press the RIGHT ARROW key for Yes or NO.

If the Sanitizer Lock option is set to YES, a low pH condition disables the sanitizer feed (ORP and Sanitizer functions).

3.5 - High Alarm

The ALARM HIGH value is set to generate an alarm when the pH reading rises above the set value. After the alarm value is set, the ALARM OPTIONS screen is shown, asking whether a high alarm condition should stop the feeder and activate the alarm buzzer (see ORP submenus).

If the Sanitizer Lock option is set to YES, a high pH condition disables the sanitizer feed (ORP and Sanitizer functions).

3.6 - Time Limit

The TIME LIMIT sets the maximum allowed time (in minutes) for continuous acid or base feed (see ORP submenus). This acts as a safety feature to prevent overfeeding in case of malfunction of the chemical feeder or as an alarm if the feed tank runs empty. The standard (default) value for pH is 15 minutes.

When in alarm, Time Limit is reset by highlighting the value and pressing "OK". To defeat the safety timer, enter zero (0).

3.7 - Run Time

The RUN TIME line displays two separate values: the amount of running time in minutes for each current activation event and the total run time since last reset to zero.

To reset the cumulative runtime, enter zero in the far right column. To reset only the current run time, highlight Time Limit value and press "OK" (see ORP submenus).

The Total Feed Time submenu 3.7.1 is used to show the feed time from a tank since last reset to zero. Knowing the pump feed rate, it can be used to monitor the emptying of the tank and set a low-level alarm. This feature is particularly useful for remote monitoring of the chemical tanks.

3.8 - Probe Clean

The Probe Clean Menu is used for automatic rinsing of the tips of the ORP and pH sensors by injection of a cleaning solution (usually a weak acid solution) through the recirculation line.

It has three modes of operation: Off, Manual and Automatic (see Submenu 3.8).

In both the Manual and Automatic modes, it allows a recovery time for the sensors to prevent chemical overfeeding while the signal is still affected by the cleaning solution (see Submenu 3.8.1). The recommended minimum is 1 minute.

ALARM OPTIONS	
Feed lockout	<u>YES</u>
Alarm buzzer	<u>YES</u>
Sanitizer Lock	<u>NO</u>

Submenu 3.4.1

Total Feed Time	
Max (min)	<u>120</u>
Actual (min)	<u>17</u>

Submenu 3.7.1

PROBE CLEAN	
OFF	
Manual	
Auto	

Submenu 3.8

PROBE CLEAN	
Electrode Recovery	
Time (min: 1 min)	
3 min	

Submenu 3.8.1

PROBE CLEAN ON		OFF
MO	<u>19:00</u>	<u>19:05</u>
TU	<u>00:00</u>	<u>00:00</u>
WE	<u>19:00</u>	<u>19:05</u>
TH	<u>00:00</u>	<u>00:00</u>
FR	<u>19:00</u>	<u>19:05</u>
SA	<u>00:00</u>	<u>00:00</u>
SU	<u>19:00</u>	<u>19:05</u>

Submenu 3.8.2

In the Automatic mode, a 7-day weekly program is used to set up the ON and OFF times for probe cleaning any day or every day of the week (see Submenu 3.8.2).

IMPORTANT NOTE: Probe Clean is available only when Conductivity control is OFF.

4 - CONDUCTIVITY MENU

Conductivity and TDS

The Conductivity sensor monitors the concentration of **Total Dissolved Solids (TDS)** in the water. The conductivity of the water - in microsiemens per centimeter ($\mu\text{S}/\text{cm}$) - is converted into ppm or mg/l of TDS with a conversion factor that depends on the type of ionic species that are present in the water. Normally, a value of 0.5 is used for water solutions containing different species of carbonate and chloride ions (see 4.8).

Conductivity or TDS can be controlled in two different directions:

- downward (decrease) to bleed water when the TDS level gets too high, or
- upward (increase) to add a salt brine solution for an electrolytic generator when the TDS level gets too low.

IMPORTANT NOTE: Conductivity control is available only when Probe Clean control is OFF. It activates the relay labeled "Acid Clean" located on the Power board.

Conductivity or TDS Displays

Depending on the application, it may be customary to control either conductivity or TDS. The display is therefore available in the two systems, as shown on the sample screens.

To change the displays from conductivity to TDS, one simply enters a TDS factor different from 1 in Submenu (see 4.8 and 4.8.2). If the TDS Factor is 1, the display shows Conductivity in $\mu\text{S}/\text{cm}$. If different from 1, it shows TDS in ppm or mg/l.

The CONDUCTIVITY or TDS Main Menu screens are similar to the ones used for other functions, except for the extra line for SELECT SCALE.

4.1- Control Mode

Line 1 shows the Control mode that is currently selected: OFF, Manual, AUTO or Timer. To change the Control Mode, select the first line with the UP or DOWN ARROW keys and press the RIGHT ARROW key. The Control Mode screen is then displayed.

The Control Mode screen and selection procedures are common to all control functions. See CONTROL Submenus, page 45.

4.2 - Display and Calibration

Line 2 displays the current reading of conductivity in $\mu\text{S}/\text{cm}$ or TDS in ppm or mg/l. The conductivity or TDS readings are best calibrated with standard calibrated test solutions. If needed, the CALIBRATION value may be adjusted to allow for differences or changes in sensor readings.

As with all sensor calibrations, the conductivity sensor can be calibrated with 1, 2 or 3-Point calibration for origin, slope and curvature. Press the RIGHT ARROW key to enter the CALIBRATION Submenu 4.1. The calibration procedure is common to all control functions. See CALIBRATION details, page 47.

CONDUCTIVITY		AUTO
Calibrate	uS	<u>1500</u>
Setpoint	uS	<u>1500</u>
Alarm Low	uS	<u>100</u>
Alarm High	uS	<u>3000</u>
Time Limit	min	<u>30</u>
Run Time	15	<u>60</u>
Select Scale		

Menu 4

TDS		AUTO
Calibrate	ppm	<u>750</u>
Setpoint	ppm	<u>750</u>
Alarm Low	ppm	<u>50</u>
Alarm High	ppm	<u>1500</u>
Time Limit	min	<u>30</u>
Run Time	15	<u>60</u>
Select Scale		

Menu 4 (TDS Alternate)

SETPOINT	
Decrease	
Increase	

Menu 4.3.1

4.3 - Setpoint

The SETPOINT determines the conductivity or TDS level that will be maintained automatically by either dumping (bleeding) water or adding a brine solution - as determined in submenu 4.3.1. To change the setpoint, press the RIGHT ARROW key and enter the desired value with the digital keypad.

4.4 - Low Alarm

The ALARM LOW value is set to generate an alarm when the conductivity or TDS reading falls below the set value. After the alarm value is set, the ALARM OPTIONS screen is shown, asking whether a low alarm condition should stop the dump valve and activate the alarm buzzer. There is no particular danger resulting from a low TDS condition but it may be an indication of a faulty sensor.

4.5 - High Alarm

The ALARM HIGH value is set to generate an alarm when the conductivity or TDS reading rises above the set value. After the alarm value is set, the ALARM OPTIONS screen is shown, asking whether a high alarm condition should stop the dump valve and activate the alarm buzzer.

4.6 - Time Limit

The TIME LIMIT sets the maximum amount of time in minutes that is allowed for continuous dumping of water to correct a high conductivity or TDS reading. This acts as a safety feature to prevent overdumping of water in case of a malfunction of the dump valve.

When in alarm, Time Limit is reset by highlighting the value and pressing "OK". To defeat the safety timer, enter zero (0).

4.7 - Run Time

The RUN TIME line displays two separate values: the amount of running time in minutes for each current activation event and the total run time since last reset to zero.

To reset the cumulative runtime, enter zero in the far right column. To reset only the current run time, highlight Time Limit value and press "OK" (see ORP submenus).

The Total Feed Time submenu 4.7.1 is used to show the feed time from a tank since last reset to zero. Knowing the pump feed rate, it can be used to monitor the emptying of the tank and set a low-level alarm. This feature is particularly useful for remote monitoring of the chemical tanks.

4.8 - Select Scale

The Select Scale prompt takes the operator to the SELECT SCALE Submenu 4.8.

4.8.1 - Scale Selection

Submenu 4.8.1 is used to select the conversion parameters for different types of conductivity sensors. The SCALE may be set to 500, 2000, 5000, 10000, or 20000 $\mu\text{S}/\text{cm}$.

4.8.2 - Cell Constant

The Cell Constant is the aspect ratio of the conductivity sensor (length divided by cross sectional area) in cm^{-1} . It should be set according to the probe manufacturer specifications.

4.8.3 - TDS Factor

The TDS Factor is the conversion factor used to convert from conductivity readings (in $\mu\text{S}/\text{cm}$) to Total Dissolved Solids concentrations (in ppm or mg/l).

Because the conductivity of ionic species varies with the type of electronic charges, the TDS factor is somewhat empirical. For typical water treatment solutions, it is about 0.5. For instance, a Sodium Chloride solution with a conductivity of 2,000 $\mu\text{S}/\text{cm}$ contains about 1,020 ppm (mg/l) of NaCl. This indicates a TDS factor of 1020/2000 or about 0.5.

When a TDS Factor different from 1 is entered in Submenu 4.8.3, all the readings and displays are changed automatically from conductivity to TDS values. They can be changed back to conductivity by re-entering a value of 1 for the TDS factor.

Total Feed Time	
Max (min)	<u>120</u>
Actual (min)	<u>17</u>

Submenu 4.7.1

SELECT SCALE	
$\mu\text{S}/\text{cm}$	<u>2000</u>
Cell Constant	<u>1.00</u>
TDS Factor	<u>0.50</u>

Submenu 4.8

SELECT SCALE	
500 $\mu\text{S}/\text{cm}$	
2,000 $\mu\text{S}/\text{cm}$	
5,000 $\mu\text{S}/\text{cm}$	
10,000 $\mu\text{S}/\text{cm}$	
20,000 $\mu\text{S}/\text{cm}$	

Submenu 4.8.1

TDS FACTOR: <u>0.50</u>
For TDS Factor
different from 1
Display shows TDS

Submenu 4.8.3

5 - TEMPERATURE MENU

Operation

The Temperature Menu, or Heater Menu, is used to control the operation of the heater with the temperature sensor. All displays can be shown in either degrees Fahrenheit or Celsius.

The Temperature Menu screen is used to access all the Temperature submenus for Control Mode, sensor calibration, setpoint and alarm settings. It also displays the actual run time for the heater and the cumulative run time since last reset to zero.

5.1 - Control Mode

Line 1 shows the Control mode that is currently selected: OFF, Manual, AUTO or Timer. To change the Control Mode, select the first line with the UP or DOWN ARROW keys and press the RIGHT ARROW key. The control mode screen and selection procedures are common to all control functions. See CONTROL Submenus, page 45.

5.2 - Display and Calibration

The second line displays the current reading of the Temperature sensor in either temperature units.

The temperature sensor can be calibrated with 1, 2 or 3-Point calibration for origin, slope and curvature. Press the RIGHT ARROW key to enter the CALIBRATION Submenu. The calibration procedure is common to all control functions. See CALIBRATION Submenus, page 47.

5.3 - Setpoint

The SETPOINT determines the temperature level in the AUTO control mode. To change the setpoint, press the RIGHT ARROW key and enter the numerical value with the digital keypad. After pressing the OK key, the SETPOINT TYPE Submenu 5.3.1 is displayed asking whether the control is for Heating or Cooling.

The normal (default) setting is for Heating. This means that the heater is automatically activated when the temperature sensor reading falls below the setpoint. If it is set for Cooling, the cooler is activated when the temperature sensor reading is above the setpoint.

5.4 - Low Alarm

The ALARM LOW value is set to generate an alarm when the temperature reading falls below the set value. After the alarm value is set, the ALARM OPTIONS screen is shown, asking whether a low alarm condition should stop the heater and activate the alarm buzzer.

HEATER		<u>AUTO</u>
Calibrate	F	<u>80</u>
Setpoint	F	<u>80</u>
Alarm Low	F	<u>70</u>
Alarm High	F	<u>85</u>
Time Limit	min	<u>30</u>
Run Time	15	<u>60</u>
Energy Saver		<u>OFF</u>

Menu 5

SETPOINT
Heating
Cooling

Submenu 5.3.1

5.5 - High Alarm

The ALARM HIGH value is set to generate an alarm when the temperature reading rises above the set value. After the alarm value is set, the ALARM OPTIONS screen is shown, asking whether a high alarm condition should stop the heater and activate the alarm buzzer.

5.6 - Time Limit

The TIME LIMIT sets the maximum amount of time in minutes that is allowed for continuous heating to correct a low temperature reading. This acts as a safety feature to prevent overheating in case of a malfunction of the heater or sensor.

When in alarm, Time Limit is reset by highlighting the value and pressing "OK". To defeat the safety timer, enter zero (0).

5.7 - Run Time

The RUN TIME line displays two separate values: the amount of running time in minutes for each current activation event and the total run time since last reset to zero.

To reset the cumulative runtime, enter zero in the far right column. To reset only the current run time, highlight Time Limit value and press "OK".

5.8 - Energy Saver

The Energy Saver program is used to reduce the temperature when the pool is not in use in order to save energy costs. It includes a seven-day programmer for OFF and ON times and a temperature level adjustment.

6- PUMP MENU

Operation

The Pump Menu is used to monitor and control the operation of the main recirculation pump, including pressure and flow rate. It is also used for programming of pump shutoff (fireman) delay that allows time for cooling off the heater.

The main pump may be on, off, or set to start automatically. Note that it may run for the amount of time set in the HEATER DELAY after being turned off, to allow time for cooling off the heater. When PUMP model option (submenu 8.1.7) is set to YES, the alarm beeper sounds a warning beep for thirty seconds before the pump starts, in case maintenance operations are being performed.

NOTE: If the Pump function is available, all other control functions are shut down when the pump is set to OFF. No alarms occur. The controller may still be operated via the keyboard and display, or remotely by computer or telephone.

If the controller appears to be non functioning, always check that the pump is operating (small ARROW on Display Screen). This is true even if the pump is not physically connected to the controller.

6.1- Control Mode

Submenu 6.1 is used to select the Control mode: OFF, MANUAL, AUTO or TIMER.

TIMER is to be used ONLY on installations with vacuum sand filters.

When AUTO is selected, the Pump Schedule Submenu 6.1.1 is displayed. Daily ON and OFF times can be selected by the operator. **If nothing is selected, the pump stays off all the time.**

All scheduled times should be entered in the 24:00 hour format. Different times can be entered for different days. This allows for reduced costs of operation on weekends.

PUMP		<u>AUTO</u>
P influent	psi	<u>25</u>
P effluent	psi	<u>20</u>
Flow rate	gpm	<u>800</u>
Alarm low	gpm	<u>500</u>
Flow Total	Mga	<u>0.15</u>
Heater delay	min	<u>20</u>
Water Level		<u>AUTO</u>

Menu 6

PUMP	
Off	
Manual	
Automatic	
Timer	

Submenu 6.1

PUMP	ON	OFF
Mo	<u>06:00</u>	<u>20:00</u>
Tu	<u>06:00</u>	<u>20:00</u>
We	<u>06:00</u>	<u>20:00</u>
Th	<u>06:00</u>	<u>20:00</u>
Fr	<u>06:00</u>	<u>20:00</u>
Sa	<u>06:00</u>	<u>18:00</u>
Su	<u>09:00</u>	<u>18:00</u>

Submenu 6.1.1

6.2 - Influent Pressure

Line number 2 in the Pump Menu screen displays the current reading of the Influent Pressure sensor, i.e. before the first filter.

Pressure Alarms

Submenu 6.2 is used to specify the alarm limits for the influent pressure in case of malfunction of the pump, filter or valves. There is no equivalent submenu for the effluent pressure. To change the limits, (1) select the + or - sign using the right arrow, (2) press "OK", (3) enter the limit value, (4) press "OK".

Submenu 6.2.1 sets the options for the low alarm while submenu 6.2.2 sets the options for the high alarm. If set on YES, the Pump lockout alarm shuts off the main pump and the Alarm buzzer alerts the operator.

NOTE: Pressure alarms are set with a 15 seconds delay before activation. THEY CANNOT BE USED FOR ENTRAPMENT PREVENTION.

Upon exit from this submenu, the calibration submenu is displayed.

Calibration

The pressure sensor is calibrated in the Submenu 6.2.1.1 by entering two factors representing (1) the output of pressure per volt, and (2) the output in volts corresponding to zero pressure, as specified by the manufacturer of the sensor.

The factory set **default factors of 12.0 and 1.75** are valid for CHEMTROL pressure transducer Series 1200 in the pressure range of -15 to 45 psi. It should normally not require any adjustment.

NOTE: With older controller software (version 2.18 and lower), default factors of 0.43 and 1.75 should be used with CHEMTROL pressure transducer Series 1200.

6.3 - Effluent Pressure

Line number 3 in the Pump Menu screen shows the value of the Effluent Pressure, i.e. after the filter(s).

The effluent pressure sensor is calibrated in the same way as the Influent Pressure sensor.

Differential Pressure

The controller automatically calculates the value of the Differential Pressure, i.e. Influent Pressure minus Effluent Pressure.

This is one of the parameters that can be used to initiate the filter backwashing operation when it exceeds a specified value that is indicative of a dirty filter condition (see Menu 7 - Filter Menu).

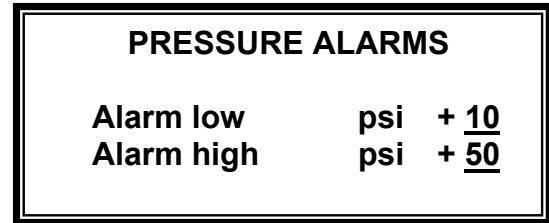

Menu 6.2

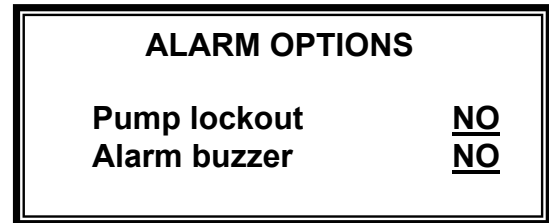

Menu 6.2.1 and 6.2.2

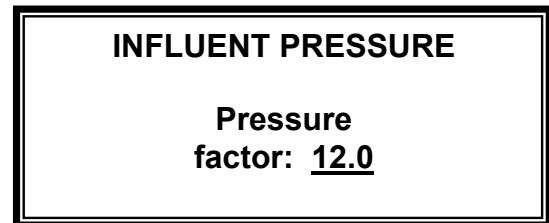

Submenu 6.2.1.1

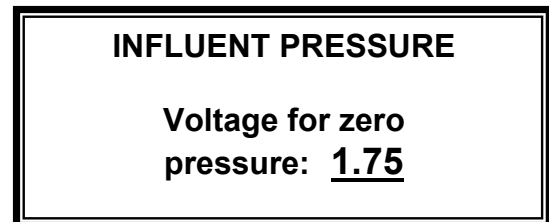

Submenu 6.2.1.2

6.4 - Flow Rate

This line displays the flow rate through the main recirculation line using input from the square wave pulse sensor. To calibrate the flow sensor, press the RIGHT ARROW key to enter Submenu 6.4.

The flow sensor is calibrated by entering the K-factor provided by the sensor manufacturer. These values correspond to the number of pulses per unit of volume in gallons or liters, which are given by the sensor manufacturer.

The values shown in the four tables below are K-factors provided by the sensor manufacturer for Schedule 80 and Schedule 40 PVC Pipes using Schedule 80 tees, saddles or iron saddle for the sensor. Additional tables are available in the sensor instruction pamphlet.

These K values however are accurate only under **ideal flow conditions that are rarely met in practice** (see Chapter II - Installation). The accuracy is somewhat better for smaller diameters. It should be noted that the readings can vary with actual flow conditions in the pipe.

For best results, the flowmeter should be calibrated by one of the following methods, listed in order of decreasing accuracy:

1. Measurement with ultrasonic flow meter,
2. Calculation from pump manufacturer curve and pressure differential before and after the pump,
3. Hydrodynamic calculations from engineering design.

If further adjustments are needed, note that **higher K values correspond to lower flow rates**.

6.5 – Low Alarm

The ALARM LOW value is set to generate an alarm when the flow reading falls below the set value.

NOTE: Flow low alarm is set with a 15 seconds delay before activation.

After the alarm value is set, the ALARM OPTIONS screen is shown, asking whether a low alarm condition should shut down the main Pump and/or activate the alarm buzzer.

6.6 - Flow Total

Line number 6 in the Pump Menu shows the cumulative flow (also called flow totalizer) in Millions of Gallons or Cubic Meters since last reset to zero or since the last backwash (for PC6000 model).

The Flow Total submenu 6.6 is used to show the cumulative flow in Gallons or Liters. To reset the cumulative flow counter, highlight the second line ACTUAL, enter 0 and push OK.

For PC6000 models, the first line MAX shows the cumulative flow threshold point (backwash is set in automatic/volume of water mode) when for comparison with the second line ACTUAL.

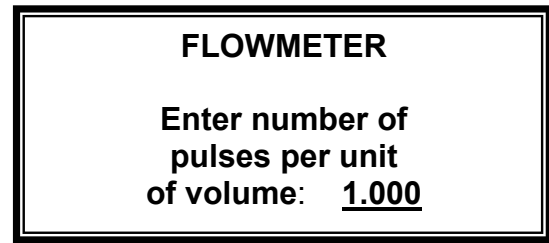

Submenu 6.4

<i>SC 80 tee/saddle</i> DIAM (in.)	<i>K-FACTOR</i> U.S. GA	<i>K-FACTOR</i> LITERS
2.0	66.739	17.633
2.5	42.994	11.359
3.0	26.652	7.041
4.0	15.006	3.964
6.0	8.325	2.199
8.0	5.016	1.325

Schedule 80 Pipe Factors

<i>SCH40 tee/saddle</i> DIAM (in.)	<i>K-FACTOR</i> U.S. GA	<i>K-FACTOR</i> LITERS
2.0	54.700	14.452
2.5	37.159	9.817
3.0	23.697	6.261
4.0	13.456	3.555
6.0	7.459	1.971
8.0	4.529	1.197

Schedule 40 Pipe Factors

<i>SCH80 iron saddle</i> DIAM (in.)	<i>K-FACTOR</i> U.S. GA	<i>K-FACTOR</i> LITERS
6.0	8.440	2.230
8.0	4.900	1.295
10.0	3.060	0.808
12.0	2.160	0.571

Schedule 80 Pipe Factors

<i>SCH80 iron saddle</i> DIAM (in.)	<i>K-FACTOR</i> U.S. GA	<i>K-FACTOR</i> LITERS
6.0	7.240	1.913
8.0	4.400	1.162
10.0	2.800	0.740
12.0	1.980	0.523

Schedule 40 Pipe Factors

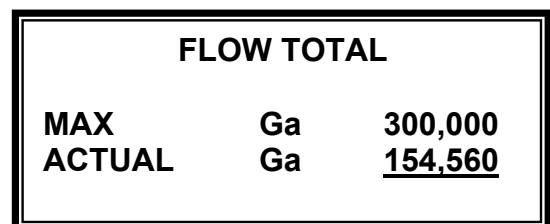

Submenu 6.6

6.7 - Heater Delay (Cooldown Safety)

The cooldown safety (or Fireman) is a delay for heater cooldown before shutoff of the main recirculation pump. It is used to protect the heater from overheating due to lack of water circulation.

The minimum value recommended by most heater manufacturers is 20 minutes. When the pump is programmed to turn off, it turns the heater off immediately and then waits 20 minutes for the water to cool down before it actually shuts off the recirculation pump.

In case of emergency, the main power supply to the pump should be turned off at the main circuit breaker.

6.8 - Water Level Control

The water level in the pool can be maintained automatically with a water level sensor (OPTION LEVEL) and fill valve.

The sensor is an electro-optical sensor (

Figure 25, Page 17) that can be located in the pool or in the surge pit (Figure 27, Page 17). The sensor uses the reflection of a LED beam inside a prism to determine the position of the water level (see Figure 26, Page 17). With no liquid present, the light beam from the LED is reflected within the prism to the receiver (circuit closed). When the liquid level reaches the prism, the beam does not reflect into the receiver (circuit open). For best results, the surface of the prism must remain clean.

This submenu is used to set the automatic fill valve to OFF, Manual or AUTO. During fill, the "LOW LEVEL" message is displayed on the Main Screen (Figure 3, Page 3).

When AUTO is selected, the Water Level Schedule Submenu 6.8.1 is displayed. Daily ON and OFF times can be selected by the operator to allow valve operation only when personnel is present.. If nothing is selected, the fill valve actuation is allowed at all the time. All scheduled times should be entered in the 24:00 hour format. Different times can be entered for different days.

NOTE: The fill valve is set to actuate with a 50 seconds delay after the sensor indicates a low level (red LED off) to avoid chattering of the relay.

6.8.2 – Feed lockout

During fill, chemistry adjustment can be put on hold by setting the Feed lockout option to YES.

6.8.3 – Time limit

The TIME LIMIT sets the maximum amount of time in minutes that is allowed for continuous valve actuation to correct a low level reading. This acts as a safety feature to prevent overflowing in case of a malfunction of the valve or sensor.

When in alarm, Time Limit is reset by highlighting the value and pressing "OK". To defeat the safety timer, enter zero (0).

6.8.4 – Run time

The RUN TIME line displays two separate values: the amount of running time in minutes for each current activation event and

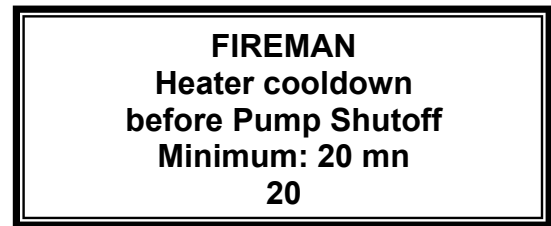

Submenu 6.7

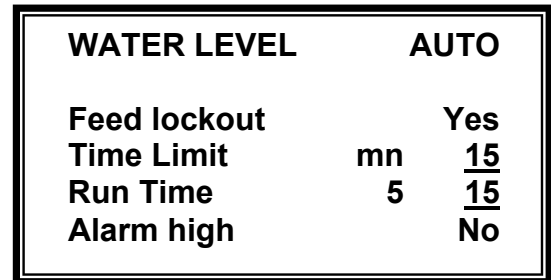

Submenu 6.8

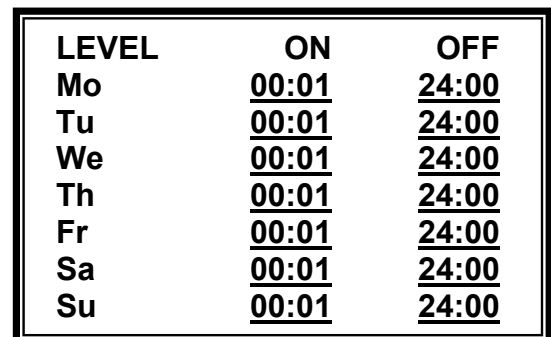

Submenu 6.8.1

the total run time since last reset to zero.

To reset the cumulative runtime, enter zero in the far right column. To reset only the current run time, highlight Time Limit value and press "OK".

6.8.5 – Alarm High (PC6000 model only)

For PC6000 model, Alarm High sets the high level alarm safety feature, used during filter backwash to avoid overflowing the waste pit.

When set to YES, the controller senses the input of the "high level" sensor and will shut off the backwash cycle if a high level is detected (open circuit). Connect the leads from the high alarm level sensor to the Terminal Barrier strip TB1 as indicated on the Mother Board Schematic (Figure 7).

7 - FILTER MAIN MENU

Filter Backwash

The Filter Menu for the CHEMTROL™ PC6000 allows the operator to set the parameters for automatic backwashing. It can be applied to one filter (Figure 8, Page 19) or to several filters (Figure 30, Page 19) with programmable sequencing of multiple filters.

During backwash operation, the "BACKWASH CYCLE" message is displayed on the Main Screen (Figure 3, Page 3).

The backwash operation is controlled with up to six (6) double-pole, double-throw (DPDT) relays to allow sequential closing and opening of backwash valves. See Filter Backwash in Chapter IV - INSTALLATION for details (Page 19).

Line 7.1 sets the BACKWASH mode to OFF, MANUAL or AUTO.

-OFF disables all backwash operations. If a backwash cycle is in progress, it is terminated immediately.

-MANUAL initiates an immediate backwash cycle.

-In the AUTO mode, the backwash cycle is initiated under programmable parameters set in Submenu 7.1. In Auto, the Backwash Schedule Submenu 7.1.1 is displayed. Daily ON and OFF times can be selected by the operator to allow backwash only when personnel is present. If nothing is selected, backwash is allowed at all the time. All scheduled times should be entered in the 24:00 hour format. Different times can be entered for different days.

Line 7.2 sets the START DATE for the first timed cycle.

Line 7.3 sets the START TIME for automatic cycles. When set to 00:00, backwash activates as soon as the threshold is reached allowing multiple backwash per day when needed.

Line 7.4 sets the backwash and rinse durations per filter. To defeat the Rinse cycle, set it to zero (0.0). If Rinse is used, a maximum of 3 filter backwash/rinse cycles are available and the rinse relays are as follows: rinse1="filter4", rinse2="filter5", rinse3="filter6".

Line 7.5 sets the delay time between filters.

Line 7.6 sets the number of filters (maximum of 6 - or 5 if Water Level control is used).

It then leads to Submenu 7.6.1 asking if a priority valve is used. This feature, which uses the De-Oxy relay is not available if the ORP control is set to Reducer or Both.

Line 7.7 shows the status of the Pump Shutdown backwash alarm. When set to YES, the pump is shut off automatically if the flow rate at the end of the cycle plus 3 minutes is not restored to at least its initial value - indicating mechanical failure.

Line 7.8 sets the PUMP OVERRIDE option to shut off the main pump during cycling of the backwash valves. This is sometime recommended to reduce pressure on the valves.

BACKWASH	<u>AUTO</u>
Start Date	<u>02/15/03</u>
Start Time	<u>15:30</u>
Filter Time (min)	<u>10.0</u>
Advance Time (min)	<u>1.0</u>
Number of Filters	<u>6</u>
Pump Shutdown	<u>YES</u>
Pump Override	<u>YES</u>

Menu 7

Time Interval
P Differential
Time or Pressure
Time & Pressure
Flow rate
Volume of water
Volume or Pressure
Volume & Pressure

Submenu 7.1

BACKWASH	ON	OFF
Mo	<u>00:01</u>	<u>24:00</u>
Tu	<u>00:01</u>	<u>24:00</u>
We	<u>00:01</u>	<u>24:00</u>
Th	<u>00:01</u>	<u>24:00</u>
Fr	<u>00:01</u>	<u>24:00</u>
Sa	<u>00:01</u>	<u>24:00</u>
Su	<u>00:01</u>	<u>24:00</u>

Submenu 7.1.1

PRIORITY VALVE ?
YES
NO

Submenu 7.6.1

7.1 - Automatic Backwash

Before accessing the setup screen, Submenu 7.1 shows a reminder indicating that the pump must be set to MANUAL or AUTO for the automatic backwash program.

Press the RIGHT ARROW key to enter the Automatic Backwash Submenu 7.1 for program selection.

After the backwash sequence is completed, the controller resets the FLOW TOTAL value located in the Pump submenu to 0 to indicate the amount of water filtered since last backwash.

7.1.1 - Time Interval

This option allows the operator to set a cycle schedule with a fixed interval of days between successive backwash operations. Pressure differential is not considered. If this option is selected, the program asks for the number of days between backwash cycles and then returns to the Backwash Submenu to specify the starting date and starting time of the day.

The standard (default) value for the backwash cycle is 14 days following the initial startup date set on the Backwash Submenu screen. It can be changed at any time by the operator.

7.1.2 - Pressure Differential

This option causes a backwash cycle to be initiated when the difference between the influent and effluent pressures at the filter exceeds the set amount. The difference entered can range from 1 to 99 psi or kg/cm².

7.1.3 - Time or Pressure Differential

This option causes a backwash cycle to be initiated when EITHER the specified interval number of days has passed OR the specified difference between the influent and effluent pressures exceeds the set amount.

The default difference value is 5 psi or kg/cm². It can be changed to any value in the range of 1 to 99 psi or kg/cm². The time interval between backwash cycles can range from 1 to 99 days.

7.1.4 - Time and Pressure Differential

This option causes a backwash cycle to be initiated when BOTH the specified interval number of days has passed AND the specified difference between the INFLUENT and EFFLUENT pressures exceeds the set amount.

The default difference value is 5 psi or kg/cm². It can be changed to any value in the range of 1 to 99 psi or kg/cm².

The time interval between backwash cycles can range from 1 to 99 days.

7.1.5 - Flow Rate

This option causes a backwash cycle to be initiated when the main recirculating flow rate, measured by the square wave flow sensor falls below the set amount.

TIMER BACKWASH

Days between
Backwash Cycles:
14

Submenu 7.1.1

PRESSURE DIFFERENTIAL

Backwash starts when
Influent Pressure minus
Effluent Pressure
exceeds: 5 psi

Submenu 7.1.2

TIME OR PRESSURE
Backwash starts when
either Time OR
Pressure Differential
is reached.

Time (days): 7
Difference (psi): 5

Submenu 7.1.3

TIME AND PRESSURE
Backwash starts when
both Time AND
Pressure Differential
are reached.

Time (days): 7
Difference (psi): 5

Submenu 7.1.4

FLOW RATE

Backwash starts when
flow rate falls below:
140 gpm

Submenu 7.1.5

7.1.6 – Volume of Water

This option causes a backwash cycle to be initiated when the volume of water accumulated since the last backwash exceeds the set amount. The default value 0 disables the function.

7.1.7 – Volume or Pressure Differential

This option causes a backwash cycle to be initiated when EITHER the specified volume of water has accumulated OR the specified difference between the influent and effluent pressures exceeds the set amount.

7.1.8 - Volume and Pressure Differential

This option causes a backwash cycle to be initiated when BOTH the specified volume of water has accumulated AND the specified difference between the INFLUENT and EFFLUENT pressures exceeds the set amount.

NOTE: 7.1.2, 7.1.3, 7.1.4, 7.1.7 and 7.1.8: if the pressure differential at the end of the backwash cycle + 3 minutes is not restored to normal clean filter operation, the Filter control mode will be turned to OFF.

NOTE: 7.1.5: if the flow rate at the end of the backwash cycle + 3 minutes is not restored to normal clean filter operation, the Filter control mode will be turned to OFF.

7.6 Priority Valve

A Priority Valve can be specified in Submenu 7.6 to allow backwashing of the filters with clean water, as shown in Figure 30.

7.7 Pump Shutdown

If set to YES, the Main Pump will be shut down if the flow rate at the end of the Backwash Cycle + 3 minutes is not restored to or above its initial value before backwash.

7.8 Pump Override

The PUMP OVERRIDE option is used to shut off the main pump during cycling of the backwash valves. This is sometime recommended to reduce pressure on the valves.

The minimum default value is 5 seconds, which shuts the pump for a total of 10 seconds (5 seconds before start of valve cycling to reduce flow and 5 seconds after to cycle valves).

VOLUME OF WATER

**Backwash starts when
Volume of water accumulated
since last backwash
exceeds: 300,000 Gal**

Submenu 7.1.6

VOLUME OR PRESSURE

**Backwash starts when
either Volume OR
Pressure Differential
is reached.**

Volume (Gal): 300,000
Difference (psi): 5

Submenu 7.1.7

VOLUME AND PRESSURE

**Backwash starts when
both Volume AND
Pressure Differential
are reached.**

Volume (Gal): 300,000
Difference (psi): 5

Submenu 7.1.8

PUMP OVERRIDE

**Stop pump before changing
backwash valves ?
YES NO**

**Time for valve motion
(min 5 sec)
10**

Submenu 7.8

CONTROL SUBMENUS

Features

The CONTROL Submenus are common to all the functions that require control of the operating variable at a fixed setpoint. This includes ORP, pH, Conductivity and Temperature.

For all functions, control can be made more effective and precise with the use of a deadband and a progressive zone.

Since they are the same for each variable, the Control Submenus are identified below with the generic letter X.

X.1 - Control Type

The Control Submenu X.1 is used to select the control type: OFF, Manual, Automatic or Timer. Use the UP and DOWN keys to highlight the desired selection and then press the RIGHT ARROW key to confirm the selection.

If the operator selects OFF, the controller turns off the feed control outlet immediately and returns to the previous menu.

If the operator selects Manual, the controller turns on the feed control outlet immediately and returns to the previous menu.

CAUTION: On Manual setting, the outlet stays on until turned off regardless of sensor readings. If the run time exceeds the Time Limit set by the operator in the specified submenu, the outlet will be turned off to prevent accidental overfeeding.

X.0.1 - Deadband

In both automatic control modes (ON/OFF and Proportional), the controller uses a deadband zone near the setpoint. This feature is designed to prevent chattering of the relay. The deadband is expressed as a percentage of the setpoint value and can be adjusted by the operator on the DEADBAND screen.

With the deadband, the outlet remains activated until the sensor reading reaches the setpoint, at which point it is de-activated. In order for the relay to be re-activated, the reading has to get outside the deadband, thus eliminating the effect of small fluctuations.

X.0.2 - Progressive Zone

The **PROGRESSIVE ZONE** is a control zone around the setpoint where the outlet activation depends on how far the sensor reading is from the setpoint (see Figure 32).

If the sensor reading is outside of the zone, then the outlet is turned on 100% of the time. The activation rate then decreases progressively as the reading nears the setpoint value. It goes to 0% when the reading reaches the setpoint.

This control mode is available in Proportional Control only (see next page). It provides more precise control than ON/OFF control and reduces overfeeding, particularly in small bodies of water.

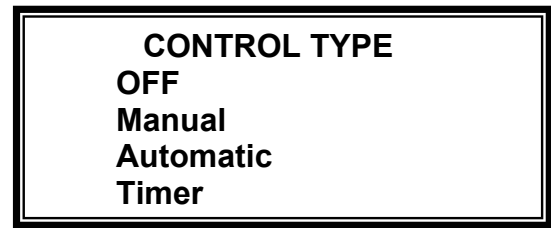

Submenu X.1

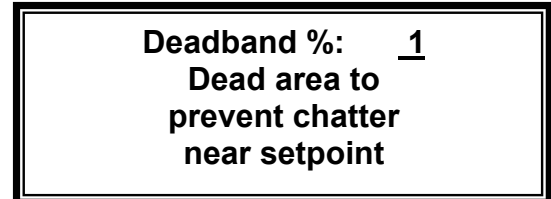

Submenu X.0.1

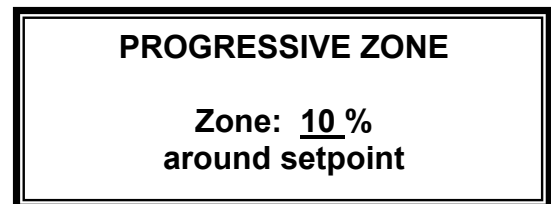

Submenu X.0.2

X.1.3 - Automatic Control

In the **Automatic Control Type**, the operator can choose among two different Control Modes: ON/OFF or Proportional, as shown on Submenu X.1.3.

X.1.3.1 ON/OFF Control

In the ON/OFF Control mode, the controller activates the control outlet until the setpoint is reached, at which point it is turned off. It is turned on again when the reading is outside of the deadband.

Selection of the ON/OFF control mode leads to the DEADBAND submenu screen X.0.1 discussed above.

X.1.3.2 Proportional Control

The Proportional Control mode is recommended only for small pools and spas to prevent overfeeding from oversized feeders. In this mode, the outlet relay is turned ON and OFF at a rate that decreases as the setpoint is neared. The rate goes down from 100% ON in a 100-second CYCLE TIME at the edge of the Progressive Zone to 0% at the setpoint (see Figure 32).

Proportional control operates only within the defined Progressive Zone (see Submenu X.0.2 on previous page). Outside the zone, control reverts to standard ON/OFF mode.

The wider the Progressive Zone is, the more slowly and precisely the controller will return to the setpoint. As the width of the Progressive Zone is decreased, the reaction becomes faster and faster until eventually, one gets near the conditions of ON/OFF control.

It should be noted that longer time limits may be required to account for the slower effective feed rates.

X.1.4 - Timer Control

In the Timer Control mode, the controller activates the control outlet according to fixed ON and OFF cycles (in minutes), regardless of sensor input. This allows programmable metered operation in case of sensor failure.

It can also be used to feed a supplementary oxidizer, as in the Automated Chloramine Treatment (ACT) process.

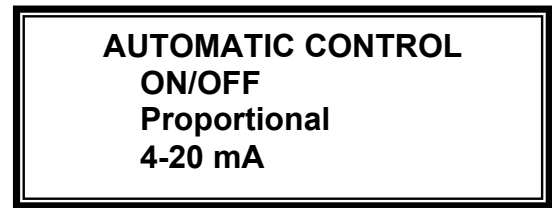

Submenu X.1.3

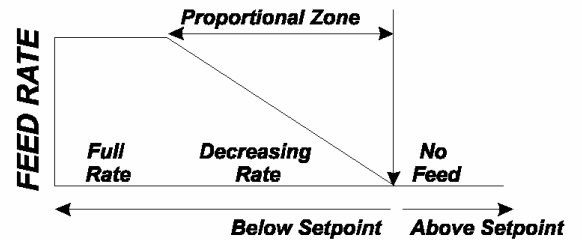
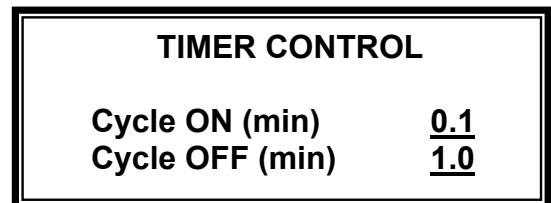

Figure 32 - Proportional Feed Rate



Submenu X.1.4

CALIBRATION SUBMENUS

X.2 - Calibration Options

The CALIBRATION Submenu is common to all the functions that require sensor calibration. This includes Sanitizer, pH, Conductivity and Temperature. It allows calibration for 1, 2 or 3-point - depending on the degree of accuracy that is required.

The CALIBRATION OPTION Submenu is used to select the number of calibration points desired. Most applications require only 1- Point calibration but any number up to three can be selected. If more than 1-point calibration is selected, the operator needs to use the required number of sample solutions. These sample solutions must be spaced sufficiently from one another to yield meaningful calibration values.

X.2.1 - One-Point Calibration

When using 1-Point calibration, the conversion curve for the sensor readings is a straight line. The slope is a default value that is built in the program.

1-Point calibration should be satisfactory for most applications. The operator places the sensor in a single water sample and tests it with an appropriate test kit. The value obtained is then entered on the calibration screen as the new display value.

The controller uses the calibration value that has been entered by the operator to calculate the origin "a" of the representative linear equation:

$$\text{DISPLAY} = a + \text{SLOPE} * \text{INPUT}$$

X.2.2 - Two-Point Calibration

With 2-Point calibration, the operator needs to use two different solutions with values that are spaced widely enough to show significant differences in the slope of the calibration curve.

The controller uses these values to calculate the origin "a" and slope "b" in the equation:

$$\text{DISPLAY} = a + b * \text{INPUT}$$

X.2.3 - Three-Point Calibration

With 3-Point calibration, the straight line is replaced by a second-degree polynomial curve. The operator needs three calibration solutions with values that are sufficiently spaced apart to show differences in the curvature of the polynomial.

The controller uses these three values to calculate the origin "a", slope "b" and curvature "c" in the equation:

$$\text{DISPLAY} = a + b * \text{INPUT} + c * \text{INPUT} * \text{INPUT}$$

CALIBRATION
1 Point (zero)
2 Point (slope)
3 Point (curve)

Submenu X.2

1-PT CALIBRATION

Point 1 **7.5**

Submenu X.2.1

2-PT CALIBRATION

Point 1 **7.5**
Point 2 **10.0**

Submenu X.2.2

3-PT CALIBRATION

Point 1 **7.5**
Point 2 **10.0**
Point 3 **4.0**

Submenu X.2.3

SHOCK AND SAVINGS SUBMENUS

X.8 - Treatment Selection

Submenu X.8 is used to select the shock treatment and savings program for ORP or SANITIZER.

The **Shock Treatment** program is used to destroy harmful elements, such as chloramines, germs and algae, by raising the oxidizer/sanitizer level on a specified schedule. This can be done either with the ORP function menu or with the Sanitizer function menu, depending on which activation outlet is used.

The **Chemical Savings** program is used to save chemicals by reducing the treatment level when the facility is not in use, such as at nighttime or on weekends.

X.8.1 - Shock Treatment Program

The Shock Treatment Submenu X.8.1 allows the operator to set the program to OFF, MANUAL or AUTO.

When set to MANUAL, the Shock Treatment program starts immediately.

When set to Automatic, the operator selects the date of the first treatment and the cycle in weeks for repeat treatments. He also sets the time to start and time to stop as well as the level of shock treatment to reach, in mV. With some chemicals, pH setpoint can temporarily be modified for a period of time before and during shock treatment.

- The Shock Schedule Submenu X.8.1.1 is displayed. Daily ON and OFF times can be selected by the operator to allow Shock only when personnel is present. If nothing is selected, backwash is allowed at all the time. All scheduled times should be entered in the 24:00 hour format. Different times can be entered for different days.

- Chemical injection stops when the set level is reached and then maintained until the end time or stops when the end time is reached.

X.8.2 - Chemical Saver Program

The Chemical Saver program may be set to OFF, MANUAL, or AUTO.

If set MANUAL, it will start immediately and will continue until changed back to OFF or placed in AUTO.

If AUTO is selected, the Weekly Scheduling Submenu X.8.3.1 is displayed.

All times are expressed in standard 24:00 time format. The operator can select any start and end time for the chemical saver program for any day of the week, as shown on the sample screen.

SHOCK AND SAVINGS	
Shock Treatment Chemical Saver	

Submenu X.8

ORP SHOCK	<u>AUTO</u>
Date	<u>02/06/03</u>
Cycle (days)	<u>7</u>
Time on pH	<u>19:00</u>
Level pH	<u>7.8</u>
Time ON Shock	<u>22:00</u>
Level ORP	<u>850</u>
Time OFF	<u>22:30</u>

Submenu X.8.1

SAVER	ON	OFF
Mo	<u>00:01</u>	<u>24:00</u>
Tu	<u>00:01</u>	<u>24:00</u>
We	<u>00:01</u>	<u>24:00</u>
Th	<u>00:01</u>	<u>24:00</u>
Fr	<u>00:01</u>	<u>24:00</u>
Sa	<u>00:01</u>	<u>24:00</u>
Su	<u>00:01</u>	<u>24:00</u>

Submenu X.8.1.1

CHEMICAL SAVER	
Saver	<u>AUTO</u>
Level	<u>650</u>

Submenu X.8.2

SAVER	ON	OFF
Mo	<u>20:00</u>	<u>06:00</u>
Tu	<u>20:00</u>	<u>06:00</u>
We	<u>20:00</u>	<u>06:00</u>
Th	<u>20:00</u>	<u>06:00</u>
Fr	<u>20:00</u>	<u>06:00</u>
Sa	<u>16:00</u>	<u>06:00</u>
Su	<u>16:00</u>	<u>06:00</u>

Submenu X.8.2.1

CHAPTER V - COMMUNICATIONS

CHEMCOM™ REMOTE OPERATION

The CHEMTROL™ PC2000 controller features remote operation by Windows™-based computers via modem-to-modem, ethernet / internet or direct connections, using the proprietary CHEMCOM™ software program.

The CHEMCOM™ program is a program for Windows™ computers that features true duplex operation. This means that any action on the remote computer is immediately implemented on the screen of the controller, and vice versa.

This unique feature is particularly useful for remote monitoring, operator training and troubleshooting.

CHEMCOM™ Program

The menu screen on Figure 33 shows that the CHEMCOM™ program is fully menu-driven and easy to use, even by staff without computer experience.

Menu 1 INSTRUCTIONS gives access to basic printable operation information.

Menu 2 SYSTEM SETUP is used primarily to setup the system communications options when connecting to controllers via modem or direct (RS-485). If unsure about the communication port setting, try COM1. If you get an error message when trying remote communications, try COM2, etc.

Menu 3 FACILITIES is the master list of facilities. Changes to individual facilities occur in this submenu. It is important to specify the model number of the controller, i.e. PC2000. To be included in automatic scanning, set the facility to A (Active).

Menu 4 SCANNING SCHEDULE is used to select the automatic scanning mode. It does not affect the Remote Operation mode.

Menu 5 ACTIVATE SCANNING is used to initiate automatic scanning or data-log download of "ACTIVE" remote facilities.

Menu 6 REMOTE CONTROL is used to access and operate any of the remote facilities.

Menu 7 SCAN FACILITIES is used to manually connect to "ACTIVE" controllers for scanning and/or data-log download.

Menu 8 DISPLAY DATA is used to display downloaded data either in graphical, "scan" table or text format.

Menu 9 FILE MANAGEMENT is used to manage downloaded data files including selective copying and erasing.

Menu 10 QUIT is used to exit the CHEMCOM™ program and return to *Windows*.

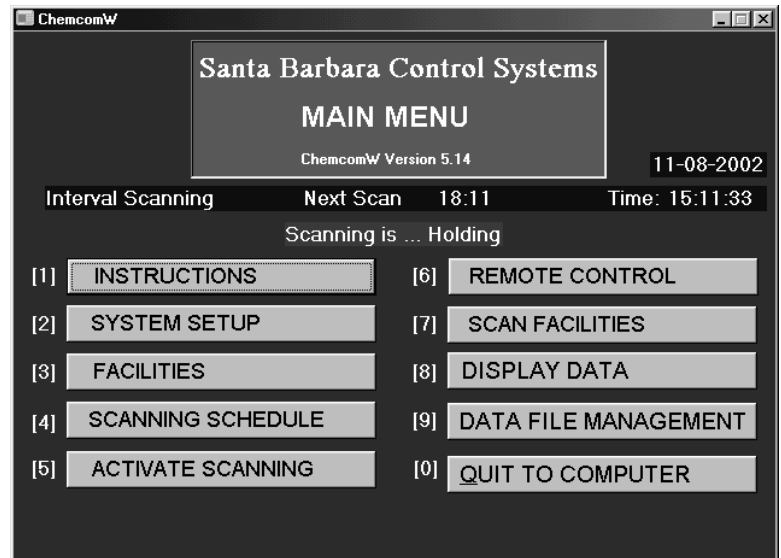

Figure 33 - CHEMCOM™ Program Menu

Computer Software Installation

The CHEMCOM™ computer software program used for remote operation is supplied on a CD-ROM. The program is self-installing and runs under *Windows*.

To install the program on the remote computer, click on Run on the Desktop screen and select the CDROM drive where the CHEMCOM™ program disk is located. Then click on Setup.

To start the program, double-click the CHEMCOM shortcut on the desktop or go to the Start/Program menu and click on the CHEMCOM icon.

To learn more about the CHEMCOM™ program, open the instructions file located on the CDROM. The file is saved in RTF (Rich Text Format) to be read or printed by any word processor.

Remote Communications

Several Remote Communications options are available for the CHEMTROL™ PC controllers:

Modem Connections

Option REM uses modem-to-modem communication between the remote computer and the on-board data modem. On CHEMTROL™ PC2000 controllers, the data modem and the standard US-type RJ11 phone jack are located on the middle right hand side of the Mother Board (see Figure 7).

Using the phone extension cable, connect the jack on the CHEMTROL™ PC to an analog telephone line (no switchboard). The phone line does not have to be a dedicated line and it can be used for other communications when not in

use for the controller. When called by a remote computer, the controller answers on the first ring, unless somebody else answers the call.

The modem on the remote computer is connected to one of the communication ports. The CHEMCOM™ program will need to know which one is used. It is usually COM1 or COM2. To confirm, click on START/Settings/Control Panel and double-click the “modems” icon.

Ethernet / Internet Connections

Option ETHCOM uses Ethernet / Internet communication between the remote computer and the on-board Ethernet modem. The Ethernet modem is typically installed inside the controller enclosure but does not install directly on the controller board.

Connect the Black and Red wires of the cable provided with the Ethernet modem to the controller RS485 A (black) & B (red) ports. Set the controller as a slave by orienting the jumper J9 as marked on the motherboard (Figure 7). Then, power and connect the Ethernet modem to the TCP/IP network via its standard RJ45 TCP/IP jack.

Direct Connections

Option RS485 establishes a direct connection between one on-site computer and the controller through a dedicated pair of wires (3,000 feet maximum) using RS485-based communication.

Connect the controller RS485 A & B ports to the computer RS485/RS232 converter through the dedicated pair of wires. Set the controller as a slave by orienting the jumper J9 as marked on the motherboard (Figure 7).

The RS485/RS232 converter on the remote computer is connected to one of the external communication ports. The CHEMCOM™ program will need to know which one is used. It is usually COM1.

Remote Operation

To establish connection from a remote computer, select Menu 6 REMOTE CONTROL on the CHEMCOM™ menu screen (Figure 33) and click on the name of the facility (**Error! Reference source not found.**).

The computer then connects to the controller and displays an image of the actual controller screen in **true duplex representation**, as shown on **Error! Reference source not found.**

True duplex operation means that all the moves and operations on the remote computer screen are simultaneously executed in real time on the controller screen, and vice versa. This allows 100% remote control of all operating functions.

Navigation through the menus and submenus on the remote computer is done exactly as with the actual controller, by using the computer arrow keys or, under *Windows*, by clicking on the arrows shown on the computer screen with the mouse.

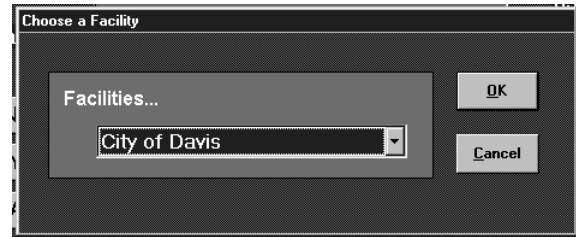

Figure 34 - CHEMCOM™ Facility Selection

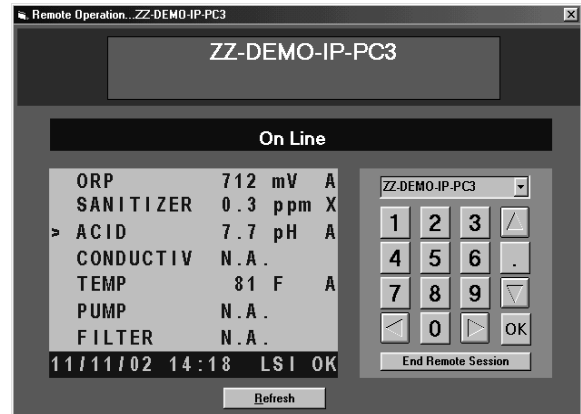

Figure 35 - CHEMCOM™ Remote Operation Screen

With CHEMCOM™, the remote operator can verify all operating conditions at a glance.

- Line 1 shows an **ORP reading of 712 mV** with the oxidizer in the Automatic mode (A).
- Line 2 shows a **Sanitizer level of 0.3 ppm** with the feed mode OFF (X).
- Line 3 shows a **pH reading of 7.7** with the Acid pump feeding (>) in the Automatic mode (A).
- Line 4 shows the **Conductivity** not available (N.A.)
- Line 5 shows a **Temperature reading of 81 F** with the heater control on Automatic (A).
- Line 6 shows the **Pump** not available (N.A.)
- Line 7 shows that the **Filter Backwash** not available (N.A.)
- Line 8 shows the **Date and Time** and the saturation condition as OK. This last line also gives access to the Configuration Menu.

Scanning Facilities

CHEMCOM offers automatic and manual scanning of facilities to connect to “ACTIVE” controllers for scanning and/or data-log downloads. When the remote controller is contacted, the test data is displayed on the computer screen and stored on disk file for later recall.

Automatic Scanning

Through Menu 4, you select and set-up the automatic scanning modes:

- Continuous: CHEMCOM scans all “ACTIVE” controllers continuously.
- Interval Scanning: Select the preferred interval (every 15 minutes, every 3 hours, etc.)
- Scheduled Scanning: Enter exact times of the day you wish scanning to occur.

Menu 5 is used to activate scanning or data-log download, following the scanning schedule set in Menu 4.

After clicking “Activate Scanning”, you must choose one of two scanning options:

1. Data-log: to download the data-logs following the start and stop dates entered.
2. Scanning: to scan the readings at the time the computer connects to them

When a scanning option is accepted, the phrase “scanning ... holding” on the Main Menu changes to “scanning is active”.

Manual Scanning

After clicking Menu 7-“Scan Facilities”, you must choose to scan all facilities or just one using one of two scanning options:

1. DATALOG: to download the controllers’ data-logs following the start and stop dates entered.
2. SCAN DATA: to scan the controllers’ readings at the time the computer connects to them.

Display of Scanning Data

When the remote controller is contacted, the test data is displayed on the computer screen indicating “successful scan”, as shown below, and stored on disk file for later review.

The three most recent stored scans of all ACTIVE facilities can be accessed by selecting the DISPLAY DATA / RECENT SCANS menu. Alarm conditions (out-of-range) are marked in red cells to facilitate the review.

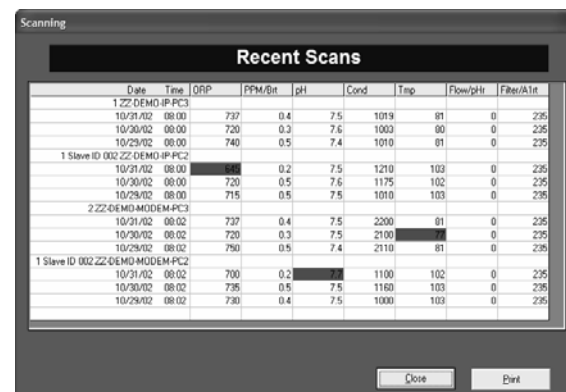
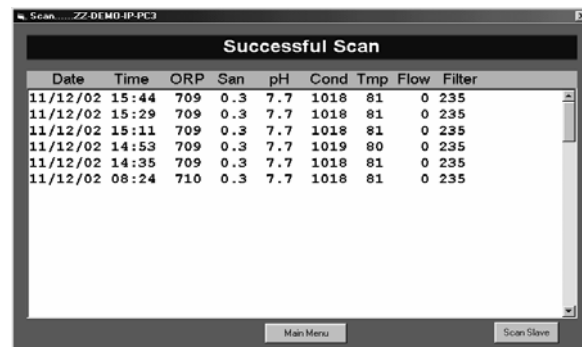
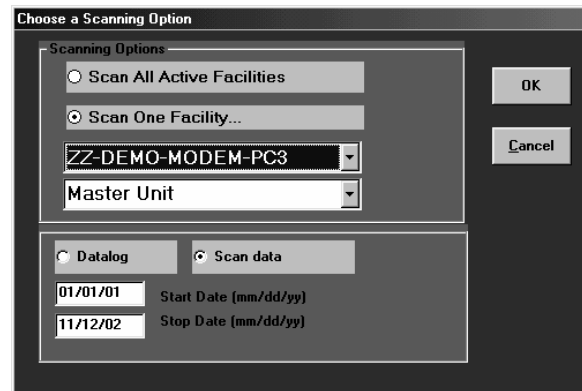
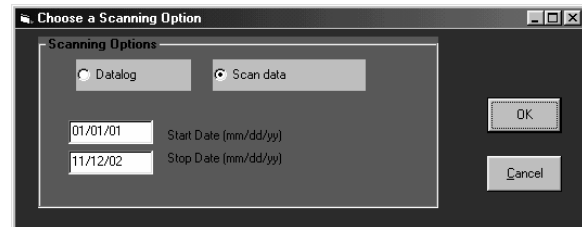
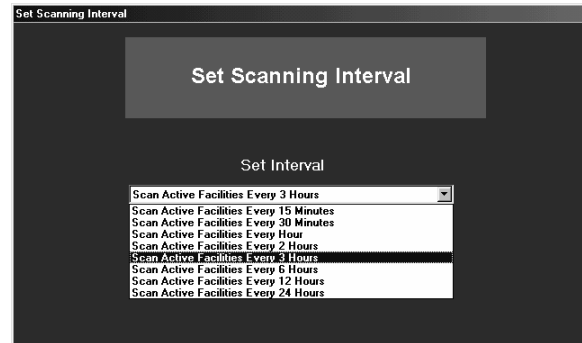

Figure 36 - CHEMCOM™ Automatic Scanning

Data Log Download

Logged data can be downloaded by remote computer via the CHEMCOM™ program, using Menu 6-REMOTE CONTROL or Menu 7-SCAN FACILITIES.

Remote Control

After connecting to the controller, navigate remotely through the controller menus to reach the OPERATIONS / PRINT REPORT submenu. Select the desired START and END dates, move to Print Data Log and press the RIGHT ARROW. A counter shows the number of tests being printed and saved on the remote computer.

Scan Facilities

After clicking “Scan Facilities”, choose to scan all facilities or just one using the datalog option to download the controllers’ data-logs following the start and stop dates entered.

On-site Download

Logged data can also be downloaded or printed on-site using the controller RS232 serial port, through the controller OPERATIONS/PRINT REPORT Submenu 6.2.4, as explained in the OPERATIONS Chapter, page26.

Text Data Display

The data is stored as a text file in the computer. It can easily be displayed as text data using Windows Notepad or any conventional word processor.

It can also be displayed directly in two formats through the CHEMCOM™ program - as shown in Figure 37 - using Menu 8 DISPLAY DATA and VIEW.

- TEXT: It is displayed as text data using the “TEXT” button;
- SCAN TABLE: It can be displayed as a “Scan table” using Menu 2 - System Setup using the established High and Low alarm values.

The test data can also be easily copied and incorporated into other documents, such as reports to management or to the health department.

Graphic Data Display

The data log can be displayed graphically with the CHEMCOM™ software program, using Menu 8 for DISPLAY DATA and PC GRAPH.

As shown on Figure 38, the graphics program displays two parameters simultaneously, such as ORP as a main variable and pH as an overlay, as shown on the right.

By clicking on the ZOOM ENABLE icon, windows can be drawn around parts of the graphs to display enlarged and more detailed views for selected dates or times. The left and right arrows allow scanning of the graph in either direction. To return to the full graph, click on ZOOM RESET.

The tool bar can be turned on to allow changes in scales, type of display and colors.

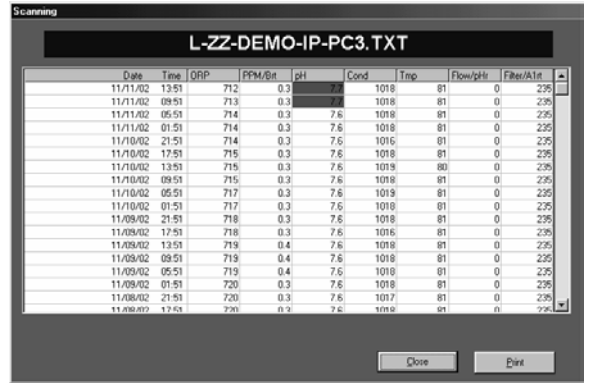
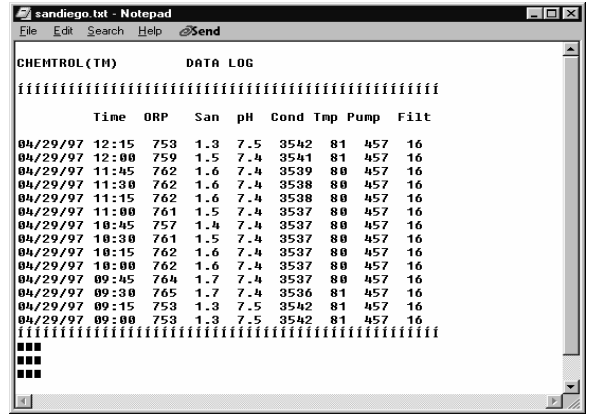

Figure 37 - CHEMCOM™ Text Data Display

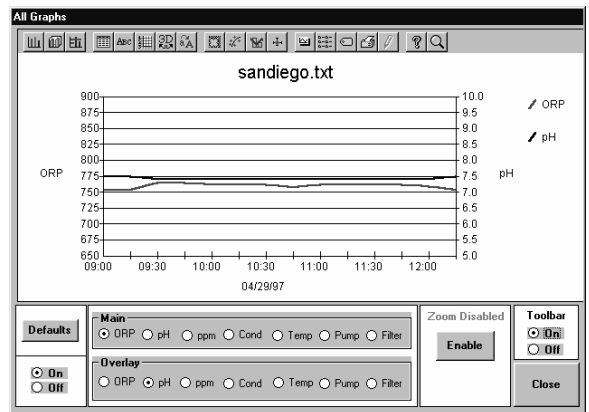

Figure 38 - CHEMCOM™ Graphic Data Display

CHAPTER VI - MAINTENANCE

CONTROLLER MAINTENANCE

Regular Maintenance

The CHEMTROL™ PC controller requires little maintenance besides cleaning of the sensors and replacement of the battery, if needed, after a long shutdown.

How often the sensors require cleaning depends on the quality and flow of water. Use the Acid Test below to check the ORP and pH sensors. For commercial and public pools or spas, it is recommended to schedule preventive cleaning programs on a weekly or monthly basis.

The Acid Test

The Acid Test is used to check the ORP and pH sensors on line.

Carefully add a small amount (½ cup or less for a public pool, a small capful for a spa) of hydrochloric (muriatic) acid HCl in the intake side of the recirculation line, upstream of the sensors, and observe the ORP and pH readings on the Main Display. After a few minutes, the pH reading should go down and the ORP reading up. After several minutes, both readings should return to their original values.

Sensor Cleaning

WARNING: The sensors stop reading when they become coated with oil, calcium or dirt.

To clean the ORP Sensor, carefully remove it from the compression fitting and clean the tip in a liquid soap solution (such as Joy, Palmolive, etc.). If it still does not work, dip it again for 5 to 10 seconds in muriatic acid (hydrochloric acid HCl). Rinse in clean water and reinsert it in the fitting.

For the pH Sensor, use the same procedure.

The electrodes of the TDS/Conductivity Sensor can be cleaned with a mild abrasive (brush or sandpaper) to remove non-conducting deposits.

Winterizing

During cold weather, the sensors must be protected from freezing. Remove both sensors from the line and store them as follows:

- store at room temperature,
- keep the protective cap on the sensor filled with water to keep the tip moist. Check periodically that there is always some water inside the cap,
- store the sensors with the tips down to prevent the air bubble from migrating toward the junction,
- soak the sensor in a salt solution if stored over 3 months.

Battery Replacement

The memory battery is located in the upper left corner of the Mother Board. It keeps the settings for configuration, operation and calibration in memory - if the power supply is shut down. A low battery condition does not affect the operation of the controller as long as the main power is on.

To check the voltage of the battery, go to Configuration / Operations / Battery to display Submenu 8.2.6 (page 27).

If the battery shows a voltage below 2.5 V, it should be replaced with a 3Vlithium battery, Panasonic CR 2330 or equivalent.

To replace the battery, turn off the power to the controller, slide out the old battery and insert the new one, making sure to set it in with the positive (+) side up.

After full power shutdown, the controller reverts to the original factory default settings. You must re-enter your own settings if they are different.

Software Upgrade

The software program in the CHEMTROL™ PC controller can be upgraded by replacing the program and display chips that are located on the Mother Board. To avoid damaging the chips, follow the procedure below carefully.

1. Disconnect all power to the unit and remove the jumper J1 next to the battery on the motherboard.
2. Locate the Display Chip U2 and the Program Chip U3 in the upper section of the board.
3. Insert a flat screwdriver under the old chip and pry it gently away from its socket. Store it as a backup.
4. Handle the new chip carefully and avoid electrostatic discharge. Identify the chip orientation with the small half-moon indent upward. **CAREFUL:** wrong installation can damage the program.
5. Make sure all the pins are straight. Insert the new chip in the socket by aligning all the pins on one side first, then on the other side, applying lateral pressure to facilitate insertion.
8. Replace the jumper in J1 and restore power to the controller. You should see the CHEMTROL™ logo displayed on the screen twice. When the display screen shows asterisks (***) for date and time, you can be assured that the old program has been erased in its entirety.
7. Reprogram the controller to the desired parameters.

CHEMICAL MAINTENANCE

Overview

For best results, it is strongly recommended to have the same operator in charge of water maintenance and testing, as different people read test kits differently.

In addition, it is recommended to check the calibration of the controller at the same time of the day, preferably in the morning after a couple of hours of operation, but before full sun. This is especially important for pools stabilized with cyanuric acid as the effects of sunlight on chlorine activity are not detected by the test kits and may lead to false and unnecessary readjustments.

Finally, the pool operator should become familiar with ORP technology (see below) and learn to trust the information it provides rather than less reliable test kits.

pH Control

The importance of proper pH control cannot be over emphasized, as it affects every aspect of water chemistry.

For pools and spas, the recommended pH setpoint is between 7.4 and 7.8. Below 7.4, the water becomes increasingly corrosive and causes stains, etching of plaster and eye irritation. Above 7.5, the efficiency of the sanitizer decreases rapidly and the water becomes too alkaline - which causes cloudiness, stains and scaling.

pH control is also affected by Total Alkalinity (TA). If it is too high (above 150 ppm), pH response is slow and requires more acid or base feed. If it is too low (under 100 ppm), pH control becomes very sensitive.

Because of the Time Lag for mixing of the chemicals in the water, there is always a fluctuation (0.1 to 0.2 pH units) above or below the setpoint, depending on the chemical feed rate.

If the pH tends to overshoot the setpoint, the Control Mode should be set to Proportional. Alternatively, the feed rate of the acid or soda feed pump can be reduced or a more dilute solution can be used (especially in a small body of water, like a spa). DO NOT CHANGE THE SETPOINT.

In an ACID FEED system, if the pH display consistently reads too high (not enough acid), the feed rate of the acid feed pump should be increased, or a stronger solution should be used. DO NOT CHANGE THE SETPOINT.

In a SODA FEED system, if the pH display consistently reads too low (not enough soda), the feed rate of the soda feed pump should be increased, or a stronger solution should be used. DO NOT CHANGE THE SETPOINT.

ORP and Sanitizer Control

The recommended control level is 1.5 to 2.0 ppm of chlorine or 3.0 to 4.0 ppm of bromine at a pH of 7.5. To be sure of proper sanitation, the ORP should always be above 650 mV.

Even if using additional purification systems, such as ozone, UV systems or metal ion systems, **THE ORP READING MUST ALWAYS BE MAINTAINED ABOVE 650 mV.**

Because of the Time Lag between injection of chemicals, mixing in pool water, and return to the sensors, it is normal to see a variation of a few tenths of a PPM around the setpoint, depending on the feed rate of the chlorinator or brominator.

If the display shows too much overshoot, the Control Mode should be set to Proportional to reduce the feed rate. DO NOT CHANGE THE SETPOINT.

If the display consistently reads below the set point, reduce the width of the Progressive Zone or set the control mode to ON/OFF to increase the feed rate. DO NOT CHANGE THE SETPOINT.

The sensor reads ORP (Oxidation-Reduction Potential) which is closely related to the FAST ACTING FREE CHLORINE (HOCl), the most effective sanitizer. The DPD and FACTS test kits - and most other controllers - however read only the combination of FAST ACTING and SLOW ACTING FREE CHLORINE (HOCl and OCl⁻). This is not very meaningful because the slow acting form of chlorine is about 80 to 100 times slower than HOCl in killing bacteria.

With proper automatic pH control, the reading on the sanitizer display is very close to test kit readings. If the pH varies too much however, the CHEMTROL_{TM} controller will show the variations in HOCl - which are not shown by normal test kits. It is normal therefore to see small differences in readings between display and test kit if the pH varies.

If the ORP reading is maintained above the recommended minimum of 650 to 750 mV, the water should be free of germs and bacteria. Below 650 mV, germs and bacteria will develop rapidly.

ORP readings are closely tied to the concentration of Fast Acting Free Chlorine (HOCl), which is affected by pH and by the cyanuric acid level. If the pH and/or cyanuric acid level is too high, the ORP will be reduced even with high levels of chlorine.

With stabilized forms of chlorine (dichlor powder or trichlor tablets), it is important to test the cyanuric acid level in the water regularly and to dump or replace part of the water when it gets over 40 ppm - especially in spas.

If other purification systems are used (ozone, UV or metal ions systems), it is very important to maintain the proper ORP level at all times with chlorine or bromine residuals.

NOTE: Make sure to shut off the Bypass Line when adding sequestering agents as they will coat the platinum ring of the ORP sensor, resulting in false readings.

Limit Timers (Overfeed Safety)

The Time Limit settings are designed to disable the feeders or other equipment in case of equipment failure or operator error such as:

- sensor or electronics failure,
- chemical feeder malfunction,
- improper valving of the recirculation system,
- manual override of automatic control by untrained or unauthorized personnel,
- depletion of chemical supply.

In normal operation, the chemical feeders are activated only for a short period - that is until the chemical level in the water has returned to the proper value. As soon as the chemical feeder is activated, the safety timer is turned on. Normally, feeding stops before the time limit is reached. The timer then resets to zero and waits for the next activation cycle.

However, if feeding continues over the preset time, the timer immediately stops the feeder and activates the overfeed alarm. After correcting the malfunction, reset the timer by momentarily setting the limit to 0 (see Chapter IV – Operation, page 22).

Timer Settings

To select the proper setting for each safety timer, the operator must take into consideration the size of the pool or spa and the feed rate of the chemical feeder. In case of doubt, make sure to consult a qualified CHEMTROL™ representative or call the factory.

NOTE 1: The chemical feeders should be properly sized for the installation so that they do not have to feed continuously for more than 3 hours - even during peak usage periods.

NOTE 2: Once tripped, the safety timer has to be reset manually by the operator after investigation and correction of the malfunction.

PERIODIC MAINTENANCE

Water Testing

1. Test the water with a reliable and fresh test kit daily or as often as required by the local health department.
2. Adjust the reading of the display if needed.
3. If the PPM or pH readings are out-of-range:
 - a. Investigate and correct the cause of the problem immediately,
 - b. Readjust the water manually if needed and recalibrate the displays.
4. If the displays cannot be recalibrated after adjustment of the water chemistry, clean the sensor tips and recalibrate the displays.
5. If the displays still cannot be calibrated, see the TROUBLESHOOTING section.

Shock Treatment

Even when maintaining the proper chlorine residual level with Chemical Automation, it is recommended to shock or superchlorinate the water periodically for the following reasons:

1. To prevent algae growth resulting from genetic adaptation of algae species to chlorine, i.e. becoming chlorine resistant.
2. In the event that the chlorine level is allowed to fall below the normal level, even for a short period (due to exhaustion of chemicals or technical malfunction), there can be formation of chloramines. These can be destroyed only by shock treatment.

WARNING: If the chloramine concentration exceeds 0.2 PPM (mg/l), it is recommended to superchlorinate at 10 times the combined chlorine level.

The shock treatment program can be set up either through the ORP Menu, using the proper daily or weekly program schedule.

Precautions

- A. During superchlorination, the Limit Safety Timer is disabled.
- B. A SHOCK treatment warning is displayed on the Display Screen when activated.
- C. The out-of-range alarms stay on as long as the oxidizer or sanitizer levels are above the high limits.

**ALWAYS MAKE SURE TO TURN
OFF THE CONTROLLER AND
SHUT OFF THE BYPASS LINE
WHEN DOING GENERAL POOL
MAINTENANCE SUCH AS
BACKWASHING OR REPAIRS.**

PORTABLE TESTER

The PORTA-PROBE II

The PORTA-PROBE II (Figure 39) is a convenient battery-operated portable tester and signal simulator that is designed to test the readings of the ORP, pH, TDS and Temperature sensors and to simulate calibrated signals for testing of the controller. It is not used to calibrate the sensors. This is done with a test kit for Free Chlorine and pH.

Battery Check

Before using the tester, it is a good idea to make sure that its 9 VDC battery is in good operating condition.

NOTE: Remember to turn off the POWER SWITCH to OFF after testing to avoid discharging the battery.

Self-Test

The PORTA-PROBE™ tester features a convenient self-testing capability. With the Power Switch ON, connect the two shielded jumper cables from each BNC simulator output to the corresponding BNC sensor input. Using the calibration screw on the front panel, you should be able to adjust the meter reading to the center of the scale. If not, the tester should be sent back for repair.

Testing of Sensors

Set the Mode Switch to TESTING.

ORP SENSOR

Connect the ORP sensor to the ORP BNC connector on top left of the tester. Turn the Selector Knob to ORP.

Place the sensor in balanced water (pH = 7.5 / PPM = 1.0 Cl). You should get an ORP reading within 650 to 750 mV.

Place the sensor in an acid solution. You should get a HIGH POSITIVE reading.

Place the sensor in a BLEACH (liquid chlorine) solution. You should get a LOW POSITIVE reading.

pH SENSOR

Connect the pH sensor to the pH BNC connector on top of the tester. Turn the Selector Knob to pH.

Place the sensor in nearly neutral water (pH = 7.5). You should get a pH reading of about -30 mV.

Place the sensor in an acid solution. You should get a HIGH POSITIVE reading.

Place the sensor in a BLEACH solution. You should get a HIGH NEGATIVE reading.

The linear scale on the right shows the conversion of millivolt readings into pH units.



Figure 39 - Portable Tester

To sensors

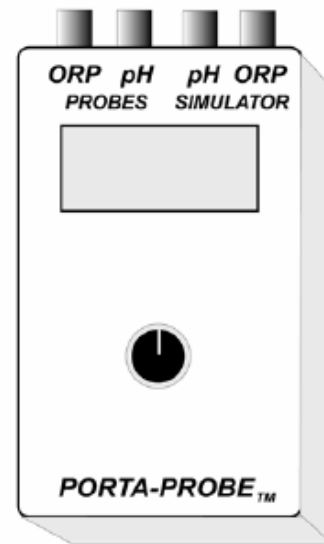

pH Scale	
mV	pH
+420	0
+30	6.5
0	7.0
-6	7.1
-12	7.2
-18	7.3
-24	7.4
-30	7.5
-60	8.0
-90	8.5
-420	14.0

TEMPERATURE SENSOR

Connect the sensor to the quick connector on the left side of the instrument. Turn the Selector Knob to TEMP READING. Place the sensor in ambient temperature water. You should be getting a correct temperature reading.

CONDUCTIVITY SENSOR

Connect the sensor to the quick connector on the left side of the instrument. Turn the Selector Knob to COND. Place the sensor in tap water. You should be getting a reading between 1,000 and 2000 μ Siemens.

To convert conductivity readings to TDS values, use a conversion factor of 0.5. For instance, a conductivity of 2,000 corresponds to a TDS value of 1,000 ppm or mg/l.

Testing the Controller

Set the Mode Switch to SIMULATOR.

ORP AND pH SIMULATION

Before starting ORP and pH simulation, turn off the Probe Monitor option on the controller.

Use the two coaxial cables to connect the BNC connectors on the top right of the tester to the respective BNC connectors on the controller.

Set the Selector Knob to either pH or ORP Simulator. The readings on the controller should match the readings of the tester display (unless offset by calibration of the pH probe).

The outputs of the ORP and pH simulators can be adjusted with the two small knobs located below the digital display. The ORP range is 0 to 1,000 mV. The pH range is -180 to + 180 mV (10 to 4 on the pH scale). These outputs can be used to test for proper operation of the feed and alarm features of the controller.

NOTE 1: Due to signal stabilization, the readings on the controller may take up to 10 seconds to reach full value.

NOTE 2: The ORP and pH signals can be simulated at the same time but only one signal is shown on the tester display.

TEMPERATURE AND TDS SIMULATION

Use the jumper wires to connect the quick connectors on the right side of the tester to the temperature and conductivity inputs on the motherboard inside the controller.

The temperature simulator is set for a fixed output of 80 °F (26.7 °C).

The conductivity simulator is set for a fixed output of 2,000 μ Siemens or about 1,000 ppm (mg/l) of Total Dissolved Solids.

To controller

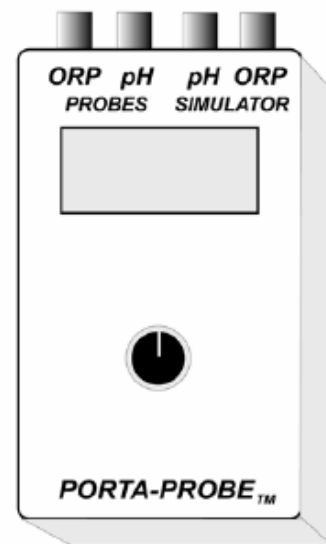

TROUBLESHOOTING

PROBLEMS	SOLUTIONS
1. NO DISPLAY.	1a. Check power to system. 1b. Check On/Off Switch on right side of cabinet. 1b. Check Voltage Selector Switch in upper section of Power Board. Verify proper input voltage 110V or 230V. 1d. Check Fuse F2 on Power Board. If blown, replace with AGC1 fast blow fuse..
2. FAINT OR DARK DISPLAY	2a. Adjust contrast with Display Potentiometer R39 in center of Mother Board.
3. ERRATIC DISPLAY.	3a. Turn Power Switch off for 10 seconds and back on. 3b. Check power cable contacts. 3c. Check power strip connecting Mother Board and Power Board. 3d. Press program and memory chips on Mother Board to assure proper contacts.
4. NO CHEMICAL FEED NO HEATER ACTIVATION NO VALVE ACTIVATION	5a. Check flashing line in Main Display Screen. Highlight flashing line with UP or DOWN arrow. Press RIGHT arrow to enter submenu. Check flashing line in Submenu. 5b. If LOW or HIGH ALARM is flashing: Adjust water chemistry manually. Press RIGHT arrow to change alarm limits. Set Feed Lockout to Off (CAUTION !!!). 5c. If TIME LIMIT line is flashing: Increase chemical feeder rate. Increase Limit Timer setting. Reset Time Limit with AUTO setting. 5d. If BYPASS LINE is flashing on Main Display: Check water flow in bypass line. Check Safety Flow Switch in bypass line. Set Bypass Line to Off in Operations Submenu (CAUTION !!!). 5e. Set Feed Mode to MANUAL. Feed Indicator on Main Display should turn on. 5f. Check Relay Fuses on Power Board. ORP: Fuses F4 and F5 Sanitizer: Fuses F10 and F11 pH: Fuses F8 and F9 Heater: Fuses F4 and F5 TDS: Fuses F4 and F5 Filters: Fuses F4 and F5
8. CANNOT CALIBRATE	NOTE: The ORP needs to be above 650 mV for Sanitizer calibration. 6a. Check water balance and adjust if needed. 6b. Clean faulty sensor as indicated. 6c. Check sensor connections. 6d. Check sensor with the PORTAPROBE™. 6e. Test electronics with the PORTAPROBE™.
7. CHLORINE OR pH OVERFEED	7a. Clean and test the faulty sensor. 7b. Check and adjust the calibration. 7c. Check and adjust the setpoint. 7d. Check the relay. 7e. Check the chemical feeder for leaks. 7f. Reduce feed rate or dilute the solution. 7g. Check the Superchlorination Program.
8. IMPROPER READINGS	8a. Clean the faulty sensor. 8b. Test the sensor with the PORTAPROBE™. 8c. Test the electronics with the PORTAPROBE™.

PARTS, ACCESSORIES AND UPGRADES

ORP	ORP SENSOR with 10-ft (3-m) shielded cable and BNC connector.
pH	pH SENSOR with 10-ft (3-m) shielded cable and BNC connector.
TEMP	TEMPERATURE SENSOR, 1/4" MPT, 10-ft (3-m) cable
T/C	TEMPERATURE + CONDUCTIVITY SENSOR with 10-ft (3m) cable.
PWFS	ROTARY SAFETY FLOW SWITCH, 1/2" FPT, for bypass line.
MB6000	MOTHERBOARD, electronic PC board for PC6000 with microprocessor.
PB6000	POWER BOARD, electronic PC board for PC6000 with relays (specify).
MB3000	MOTHERBOARD, electronic PC board for PC3000 with microprocessor.
PB3000	POWER BOARD, electronic PC board for PC3000 with relays (specify).
4-20 mA	COMMUNICATIONS BOARD for 4-20 mA input or output (specify), 5 channels.
PTR	THERMAL PRINTER, 40-column digital, 110V or 230V (specify)
BPL	BYPASS LINE ASSEMBLY, ½-in with Y-filter, flowmeter, safety flow switch, three (3) ball valves ...
SC	SENSOR CELL, 3 1/2-inch PVC cell, clear cover, two (2) ½-inch compression fittings,
FCA	FLOW CELL ASSEMBLY, PVC sensor cell, two (2) ½-inch compression fittings, sampling tap, two (2) 1/2-inch ball valves.
SCA	SENSOR CELL ASSEMBLY with Flow Cell Assembly.
205T	PVC SOLENOID VALVE for erosion feeder, 1" or 3/4" FPT (specify 24 V or 110VAC).
REM3	UPGRADE for remote operation via modem with true duplex CHEMCOM™ software
ETHCOM3	UPGRADE for remote operation via Ethernet with true duplex CHEMCOM™ software
RS485	UPGRADE for direct computer operation with communication converter and true duplex CHEMCOM™ Windows software
MULTI3	UPGRADE for Multiplex communications through host controller with RS485 and modem
RS485	UPGRADE for direct computer operation with communication converter and true duplex CHEMCOM™ Windows software
S45M3-V	MULTIPOINT SOLENOID VALVE, 3-way, 3-position motorized ball valve, PVC body, 2" FPT, 110 VAC, 150 psi for electrically operated filter backwash.
8221G2	SOLENOID VALVE, 3-way, brass body, 3/8" FPT, Normally Closed (NC), for hydraulically operated filter backwash.
8262G208	SOLENOID VALVE, brass body, 1/4" FPT, Normally Open (NO), for pneumatically operated filter backwash..

INDEX

115 V power input	7	Electrical interference.....	14
230 V power input	7	Electrolytic chlorine generators	14
4-20 mA Converter	11	EPD Filters	19
AC power input.....	7	Erosion feeder.....	18
Acid Feed	33, 54	Etching of plaster	54
Acid Test	53	Eye irritation	54
Air break	18	Feed pumps	18
Alarm	29, 34, 35, 37	Feeder Sizing	18
Algae	55	Filter backwash	19, 42
Alkalinity	1	Fireman	41
Audio Alarm	25	Flow Rate	40
Automatic backwash	42	Flow sensor.....	40
Automatic control.....	46	Flowmeter	12
Backwash	19, 42	Free chlorine	1, 31, 54
Bacteria	1, 54	Fuses	9
Base Feed.....	33	Gas chlorine.....	18
Battery	27, 53	Germs	54
Brightness	3, 9	GFI	7
Bromine	1, 18	Grounding	7
Bromine level.....	54	Health Departments	1
Buzzer	9, 25	Heater cooldown	41
Bypass Line Assembly	12	Heater Delay	41
Cal hypo tablets.....	18	Heater Menu	37
Calcium hypochlorite.....	18	High Alarm	30
Calibration	20	HOCl	20
Calibration of sensors.....	54	Hydraulic valve.....	19
Calibration Submenu.....	47	Hypochloric acid.....	20
Caustic soda.....	18, 20	Identification	28
Chemical feed pumps.....	18	Indoor pool.....	1
Chemical saver.....	30, 48	Influent pressure	39
Chemical tanks.....	18	Initial setup.....	23
Chemistry adjustment.....	20	Installation of Sensors	12
CHEMTROL™ Automation	1, 5, 49, 53	Interlock	iii, 7
Chips upgrade	53	Jumpers	7
Chloramines	55	Keyboard.....	3, 9
Clarity	1	Langelier Saturation Index	25
Clock	24	Language	23
Coliforms	1	Laptop	26
Combined chlorine	1	Last Shock	30
Communication parameters	26	LCD display.....	3, 4, 9
Communications Submenu	28	Level alarm	30, 34, 36
Compression gland fittings	12	Liquid chlorine	18
Conductivity.....	2	Location	5
Conductivity Menu	35	Low level alarm	30, 34, 36
Conductivity Sensor	15	Manual control.....	45
Configuration Menu	22	Metal ion systems	54
Control Submenu	45	Metric units.....	23
Control type	45	MIAMI TANK filters.....	19
Corrosion.....	25, 54	Microprocessor.....	9
Cumulative flow	40	Model options.....	24
Current leakage.....	14	Modem	10
Cyanuric acid.....	1, 54	Modem Certification	10, 49
Data download	26	Mother board.....	7
Data entry.....	3	Motorized valves	19
Data logging	24	Multiple Connections.....	10
Data storage.....	26	Multiple filters	19
Deadband.....	21, 45	Multiplexing	10
Default setup	22	Muriatic acid.....	18, 20
Dichlor	18, 54	NaOCl	18
Display screen.....	3	NaOH	20
DOS download	26	National Spa and Pool Institute	1
Download	26	Night control.....	21
DPD test kit	21, 54	ON/OFF control.....	46
Electrical.....	7	Operations submenu.....	25
Electrical code.....	5, 7	Options.....	24

ORP	2, 31	Sanitizer Lock.....	34
ORP Menu.....	29	Sanitizer Menu	31
ORP minimum	54	Saturation Index.....	25
ORP Sensor.....	14	Savings Submenu	48
OTO test kit.....	21	Scaling	25
Outdoor pool.....	1	Sensor testing	56
Out-of-range alarm	25	Sensor Warranty	15
Overfeed.....	54	Serial Connections	10
Overfeed Safety	55	Serial printer.....	26
Overfeeding.....	18	Setpoint adjustment	54
Oxidation-Reduction Potential.....	2, 31	Shock Submenu.....	48
Oxidizer calibration.....	21	Shock treatment.....	30, 48
Oxidizer feed	29	Shutoff Delay.....	38
Ozone.....	54	Signal generator.....	56
Panel interlock.....	7	Sizing	18
Passwords.....	23	Soda ash	18, 20
PC boards	7	Soda feed.....	20, 54
Periodic maintenance.....	55	Sodium bisulfate.....	20
pH calibration	20	Sodium hypochlorite.....	18
pH Menu.....	33	Software upgrade	53
pH Sensor	14	Solenoid valves.....	19
pH setpoint	21, 54	Spa.....	1
pH variations	54	Stabilized chlorine	1, 18, 54
pH, high.....	20, 54	Stains	54
pH, low	20, 54	STARK filters.....	19
Phenol Red test kit	33	Storage and Winterizing.....	15
Phone Jack.....	10, 50	Superchlorination	55
Phone numbers	28	Superoxidation	30, 32
Plaster	54	Tanks Sizing	18
Plate count	1	TDS.....	1, 35
Pneumatic valves	19	TDS Menu	35
Portable tester	56	Technical support.....	5
PORTA-PROBETM	56	Temperature Menu.....	37
Potentiometric sensors	12	Temperature Sensor	15
Power Board.....	7	Test kit	33
Power interlock.....	7	Testing controller.....	56
Power transformer.....	7	Time Lag	54
Pressure	39	Time limit.....	30, 34, 36, 37, 45
Print reports.....	26	Timer control	46
Priority valve.....	19	Total Alkalinity.....	1, 54
Probe Failure Analysis	2, 27	Total Dissolved Solids.....	1, 35
Program upgrade	53	Total feed Time	30, 34, 36
Progressive zone.....	45, 46	Transformer	7
Proportional control	45, 46	Trichlor	18, 54
Proportional mode	54	Trichlorinator	18
Public pools	1	Troubleshooting	57
Pump override.....	42, 44	Turnover rate.....	1
PVC tee.....	12	Unit system	23
Readings	24	Unpacking	5
Redox.....	2	Upgrade	53
Reducer feed.....	29	US units	23
Reference signals.....	56	UV systems.....	54
Relays	9	Voltage selector	7
Remote communications.....	3	Water flow	13
Remote data download	27	Water Level.....	41
Remote operation.....	50	Water level control	17, 41
Reset.....	27	Water level sensor	17
Run time	30, 34, 36, 37	Water Maintenance	1
Runtime	30, 34, 36, 37, 41	Water sampling.....	12, 20
Safety flow switch	12	Weekend control	21
Sanitizer calibration	21	Windows 3.1 download	26
Sanitizer concentration.....	2	Windows 95 download	26
Sanitizer control.....	54	Winterizing	53
Sanitizer level.....	54	Y-filter.....	12

NOTES

YOUR CHEMTROL™ PC6000 / PC3000 SETUP

ORP
 Calibrate mV _____
 Setpoint mV _____
 Alarm Low mV _____
 Alarm High mV _____
 Time Limit min _____
 Run Time _____
 Last Shock 00/00/00

OFF Manual Automatic Timer ——— ON/OFF Proportional ——— Deadband _____
 ——— Deadband _____ Prog. Zone _____

Oxidizer Reducer Both ALARMLOW Feed Lockout Buzzer _____ ALARMHIGH Feed Lockout Buzzer _____ TOTAL FEED TIME MAX TIME _____

SHOCK
 Date _____
 Cycle (days) _____
 Time ON pH _____
 Level pH _____
 Time ON shock _____
 Level ORP _____
 Time OFF _____

SANITIZER
 Calibrate ppm _____
 Setpoint ppm _____
 Alarm Low ppm _____
 Alarm High ppm _____
 Time Limit min _____
 Run Time _____
 Last Shock 00/00/00

OFF Manual Automatic Timer ——— ON/OFF Proportional ——— Deadband _____
 ——— Deadband _____ Prog. Zone _____

Oxidizer Reducer Both ALARMLOW Feed Lockout Buzzer _____ ALARMHIGH Feed Lockout Buzzer _____ TOTAL FEED TIME MAX TIME _____

SHOCK
 Date _____
 Cycle (days) _____
 Time ON pH _____
 Level pH _____
 Time ON shock _____
 Level ORP _____
 Time OFF _____

pH
 Calibrate _____
 Setpoint _____
 Alarm Low _____
 Alarm High _____
 Time Limit min _____
 Run Time _____
 Probe Clean _____

OFF Manual Automatic Timer ——— ON/OFF Proportional ——— Deadband _____
 ——— Deadband _____ Prog. Zone _____

Acid Feed Base Feed Both ALARMLOW Feed Lockout Buzzer _____ ALARMHIGH Feed Lockout Buzzer _____ TOTAL FEED TIME MAX TIME _____

PROBECLEAN ON OFF
 Mo _____
 Tu _____
 We _____
 Th _____
 Fr _____
 Sa _____
 Su _____

TDS
 Calibrate ppm _____
 Setpoint ppm _____
 Alarm Lo ppm _____
 Alarm Hi ppm _____
 Time Limit min _____
 Run Time _____
 Select Scale _____

OFF Manual Automatic Timer ——— ON/OFF Proportional ——— Deadband _____
 ——— Deadband _____ Prog. Zone _____

Decrease Increase ALARMLOW Feed Lockout Buzzer _____ ALARMHIGH Feed Lockout Buzzer _____ TOTAL FEED TIME MAX TIME _____

Cell Constant _____
 TDS Factor _____

HEATER
 Calibrate F _____
 Setpoint F _____
 Alarm Low F _____
 Alarm High F _____
 Time Limit min _____
 Run Time _____
 Energy Saver _____

OFF Manual Automatic Timer ——— ON/OFF Proportional ——— Deadband _____
 ——— Deadband _____ Prog. Zone _____

Heating Cooling ALARMLOW Feed Lockout Buzzer _____ ALARMHIGH Feed Lockout Buzzer _____

SAVER ON OFF
 Mo _____
 Tu _____
 We _____
 Th _____
 Fr _____
 Sa _____
 Su _____

PUMP
 P influent psi _____
 P effluent psi _____
 Flow Rate gpm _____
 Alarm lo gpm _____
 Flow Total Mga _____
 Heater Delay min _____
 Water Level _____

PUMP ON OFF
 Mo _____
 Tu _____
 We _____
 Th _____
 Fr _____
 Sa _____
 Su _____

PRESSURE INFLUENT
 Low psi _____
 High psi _____

ALARMLOW Pump Lockout Buzzer _____
 ALARMHIGH Pump Lockout Buzzer _____

FLOWMETER FACTOR Pulses/ga: _____
 ALARMLOW Pump Lockout Buzzer _____

WATER LEVEL
 Feed lock gpm _____
 Time limit min _____
 Run Time _____
 Alarm High _____

FILTER
 Backwash Date _____
 Start Time _____
 Filter Time (min) _____
 Advance (min) _____
 Number of Filters _____
 Pump shutdown _____
 Pump Override _____

Time Interval P Differential Time or Pressure Time & Pressure Flow rate Volume of water Volume or Pressure Volume & Pressure

BACKWASH ON OFF
 Mo _____
 Tu _____
 We _____
 Th _____
 Fr _____
 Sa _____
 Su _____

No of Filters _____
 Priority Valve _____

PUMP Override Stop Time between valves (sec) _____

MODEL OPTIONS
 ORP _____
 SANITIZER _____
 pH _____
 CONDUCTIVITY _____
 HEATER _____
 PUMP _____
 FILTER _____

CONFIGURATION
 Initial Setup _____
 Operations _____
 Communications _____

OPERATIONS
 Audio Alarms _____
 Bypass Line _____
 Probe Monitor _____

SATURATION
 Alkalinity _____
 Hardness _____

COMMUNICATIONS
 Phone _____
 Unit ID _____
 Alarm calling _____